



An EFCO Company

SWAPLOADER[®]

"Hooked on Quality"

U.S.A. LTD.



ALL-MODEL SPECIFICATIONS



ONE TRUCK **UNLIMITED** **POSSIBILITIES**



- ▶ **QUALITY**
- ▶ **INTEGRITY**
- ▶ **INNOVATION**
- ▶ **SUPER SERVICE**



WHAT COULD YOU DO WITH A **SWAPLOADER** TODAY?



HOOKED ON **QUALITY**



ALL-MODEL SPECIFICATIONS

MODEL		SL-75	SL-105	SL-160	SL-212	SL-214	SL-220	SL-222	SL-240	
MODEL DESCRIPTION	LIFT/DUMP CAPACITY (INCLUDING CONTAINER)	7,500 lb	10,500 lb	16,000 lb	20,000 lb	20,000 lb	22,000 lb	22,000 lb	24,000 lb	
	DUMP ANGLE	56°	58°	56°	58°	57°	53°	53°	53°	
	HOIST WEIGHT ¹⁰	FIXED	1,290 lb	1,570 lb	2,300 lb	2,540 lb	2,760 lb	4,080 lb	4,110 lb	3,920 lb
ADJ.		N/A	N/A	2,450 lb	2,680 lb	2,910 lb	4,270 lb	4,330 lb	4,150 lb	
GENERAL DIMENSIONS (SEE DIAGRAM)	HOOK TO REAR ROLLER (DIM. A)	114.38"	116.00"	139.63"	138.00"	153.63"	193.81"	179.81"	159.81"	
	HOOK HEIGHT (DIM. B)	FIXED	35.63"	35.63"	35.63"	35.63"	35.63"	53.88"	53.88"	53.88"
		ADJ.	N/A	N/A	35.63" / 53.88"	35.63" / 53.88"	35.63" / 53.88"	53.88" / 61.75"	53.88" / 61.75"	53.88" / 61.75"
	HOIST HEIGHT (DIM. C)	5.25"	5.5"	7.5"	7.5"	7.5"	9"	9"	9"	
	HOIST CG (DIM. D)	59.7"	58.1"	70.65"	64.0"	80.3"	97.8"	95.2"	88.0"	
	OPTIMUM BODY LENGTHS (DIM. E)	10' - 12'	10' - 12'	12' - 14'	12' - 14'	14' - 16'	18' - 20' ¹	16' - 18'	14' - 16'	
	POTENTIAL BODY LENGTHS ¹ (DIM. E)	9' - 13'	10' - 13'	10' - 15'	10' - 16'	12' - 18'	14' - 22'	14' - 20'	12' - 18'	
BODY LONGSILL WIDTH ²	41.63"/39.00"	41.63"	41.63"/40.50"	41.63"/40.50"	41.63"/40.50"	41.63"/40.50"	41.63"/40.50"	41.63"/40.50"		
HYDRAULIC SYSTEMS	HYDRAULIC PUMP TYPE (CID)	Gear (0.85)	Gear (1.86)	Gear (2.96)	Gear (2.96)	Gear (2.96)	Gear (4.46)	Gear (4.46)	Gear (4.46)	
	FLOW @ PUMP RPM ³	3.1 GPM @ 1,000 RPM	7.2 GPM @ 1,000 RPM	11.4 GPM @ 1,000 RPM	11.4 GPM @ 1,000 RPM	11.4 GPM @ 1,000 RPM	17.4 GPM @ 1,000 RPM	17.4 GPM @ 1,000 RPM	17.4 GPM @ 1,000 RPM	
	RELIEF PRESSURE	3,250 PSI	3,250 PSI	3,250 PSI	3,250 PSI	3,250 PSI	2,800 PSI	2,800 PSI	2,800 PSI	
	HYDRAULIC RESERVOIR	7 gal	15 gal	15 gal	15 gal	15 gal	25 gal	25 gal	25 gal	
LIFT CYLINDER	TYPE	ALL MODELS INCORPORATE DOUBLE-ACTING CYLINDERS WITH DUAL BUILT-IN COUNTERBALANCE VALVES.								
	QUANTITY	1	2	2	2	2	2	2	2	
	BORE	Ø 4"	Ø 4"	Ø 5"	Ø 5.5"	Ø 5.5"	Ø 6"	Ø 6"	Ø 6"	
	STROKE	38"	38"	43"	46"	54"	54"	54"	54"	
JIB CYLINDER	TYPE	⁵ MODELS INCORPORATE A SINGLE, DOUBLE-ACTING CYLINDER WITH A SINGLE BUILT-IN COUNTERBALANCE VALVE.								
	QUANTITY	2	1	1	1	1	1	1	1	
	BORE	Ø 1.5"	Ø 2.5"	Ø 3"	Ø 3"	Ø 3"	Ø 3.5"	Ø 3.5"	Ø 3.5"	
	STROKE	20"	24"	32"	32"	36"	48"	34"	30"	
TRUCK SPECS (RECOMMENDED)	GVW RANGE ⁶	14,000 lb - 16,000 lb	16,000 lb - 19,000 lb	18,000 lb - 26,000 lb	25,000 lb - 35,000 lb	25,000 lb - 35,000 lb	25,000 lb - 35,000 lb	25,000 lb - 35,000 lb	25,000 lb - 35,000 lb	
	CAB-AXLE DIM. (SINGLE AXLE) ⁷	84" - 96"	84" - 96"	108" - 120"	108" - 120"	120" - 138"	156" - 174"	142" - 160"	130" - 144"	
	CAB-TRUNNION DIM. (TANDEM AXLE) ⁷	N/A	N/A	N/A	N/A	N/A	148" - 160"	134" - 146"	118" - 130"	
	CLEAR FRAME RAIL ⁸	126"	130"	153"	156"	172"	220"	206"	186"	
	FRAME HEIGHT	up to 38"	up to 40"	up to 40"	up to 40"	up to 40"	up to 43"	up to 43"	up to 43"	
PTO SPECS (RECOMMENDED)	PUMP MOUNT ⁹	Direct Mount SAE A, 2 Bolt	Direct Mount SAE B, 2 Bolt	Direct Mount SAE B, 4 Bolt	Direct Mount SAE B, 4 Bolt	Direct Mount SAE B, 4 Bolt	Direct Mount SAE B, 4 Bolt	Direct Mount SAE B, 4 Bolt	Direct Mount SAE B, 4 Bolt	
	TORQUE REQUIRED	40 ft-lbf	80 ft-lbf	125 ft-lbf	125 ft-lbf	125 ft-lbf	200 ft-lbf	200 ft-lbf	200 ft-lbf	

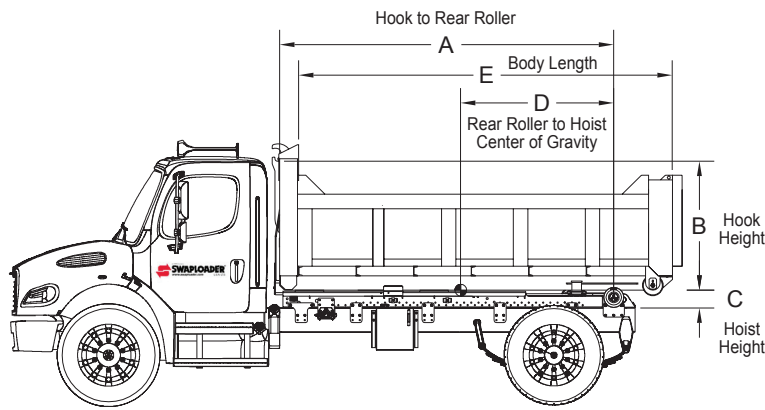

SL-2418	SL-330	SL-400	SL-412	SL-418X	SL-518X	SL-520X	SL-650
24,000 lb	33,000 lb	40,000 lb	40,000 lb	40,000 lb	50,000 lb	50,000 lb	65,000 lb
57°	58°	58°	60°	58°	58°	60°	54°
2,870 lb	5,090 lb	5,240 lb	4,860 lb	5,900 lb	5,900 lb	6,200 lb	8,190 lb
N/A	5,250 lb	5,410 lb	5,020 lb	6,040 lb	6,040 lb	6,340 lb	N/A
118.00"	167.50"	167.50"	143.50"	201.00"	201.00"	222.75"	226.50"
53.88"	61.75"	61.75"	61.75"	61.75"	61.75"	61.75"	61.75"
N/A	61.75" / 53.88"	61.75" / 53.88"	61.75" / 53.88"	61.75" / 53.88"	61.75" / 53.88"	61.75" / 53.88"	N/A
9"	11"	11"	11"	11.5"	11.5"	11.5"	13"
63.8"	88.8"	88.8"	75.6"	105.5"	105.5"	115.0"	125.0"
10' - 12'	14' - 16'	14' - 16'	12' - 14'	18' - 20'	18' - 20'	20' - 22'	20' - 22'
10' - 13'	12' - 18'	12' - 18'	12' - 15'	14' - 22'	14' - 22'	17' - 24'	17' - 24'
41.63" / 40.50"	40.50" / 41.63"	40.50" / 41.63"	40.50" / 41.63"	40.50" / 41.63"	40.50" / 41.63"	40.50" / 41.63"	40.50" / 41.63"
Gear (4.46)	Gear (3.83)	Gear (3.83)	Gear (3.83)	Bent Axis Piston (3.84)	Bent Axis Piston (3.84)	Bent Axis Piston (3.84)	Gear (4.46)
17.4 GPM @ 1,000 RPM	22.3 GPM @ 1,500 RPM	22.3 GPM @ 1,500 RPM	22.3 GPM @ 1,500 RPM	21.0 GPM @ 1,300 RPM	21.0 GPM @ 1,300 RPM	21.0 GPM @ 1,300 RPM	26.0 GPM @ 1,500 RPM
2,800 PSI	3,500 PSI	3,500 PSI	3,500 PSI	3,850 PSI	4,650 PSI	4,650 PSI	3,500 PSI
25 gal	30 gal	30 gal	30 gal	25 gal	25 gal	25 gal	30 gal
ALL MODELS INCORPORATE DOUBLE-ACTING CYLINDERS WITH DUAL BUILT-IN COUNTERBALANCE VALVES.							
2 4	2 4	2 4	2 4	2	2	2	2
Ø 5.5"	Ø 5.5"	Ø 6"	Ø 6"	Ø 6"	Ø 6"	Ø 6"	Ø 7.5"
39"	60"	60"	56"	78.75"	78.75"	85.25"	82"
MODELS INCORPORATE A SINGLE, DOUBLE-ACTING CYLINDER WITH A SINGLE BUILT-IN COUNTERBALANCE VALVE.							
1 4	1 4	1 4	1 4	1	1	1	1
Ø 4"	Ø 4"	Ø 4"	Ø 4"	Ø 4"	Ø 4"	Ø 4"	Ø 4.5"
24"	38"	38"	48"	48"	48"	52"	52"
25,000 lb - 35,000 lb	33,000 lb or greater	45,000 lb or greater	45,000 lb or greater	45,000 lb or greater	50,000 lb or greater	50,000 lb or greater	55,000 lb or greater
84" to 96"	142" - 156"	N/A	N/A	N/A	N/A	N/A	N/A
N/A	124" - 136"	124" - 136"	103" - 115"	158" - 170"	158" - 170"	178" - 190"	183"-195"
135"	195"	195"	173"	229"	229"	248"	252"
up to 43"	up to 43"	up to 43"	up to 45"	up to 45"	up to 45"	up to 45"	up to 45"
Direct Mount SAE B, 4 Bolt	Direct Mount SAE B, 4 Bolt	Direct Mount SAE B, 4 Bolt	Direct Mount SAE B, 4 Bolt	Direct Mount SAE B-B, 4 Bolt Spline Shaft 1" 15T 16/32	Direct Mount SAE B-B, 4 Bolt Spline Shaft 1" 15T 16/32	Direct Mount SAE B-B, 4 Bolt Spline Shaft 1" 15T 16/32	Direct Mount SAE B, 4 Bolt
200 ft-lbf	200 ft-lbf	200 ft-lbf	200 ft-lbf	250 ft-lbf	250 ft-lbf	250 ft-lbf	230 ft-lbf

- 1** Hoist potential body length range may not conform with I.C.C. bumper regulations or may not achieve maximum dump angle depending on truck chassis height. Shorter bodies are available on specific models with use of a body lock with shelf assembly. Contact your SwapLoader distributor for more information.
- 2** Maximum outside to outside long sill width.
- 3** Pump RPM and Flow are dependent on engine RPM and PTO ratio.
- 4** Polished nitrided cylinder rod.
- 5** Counterbalance valve manifold.
- 6** A lower GVW will limit your payload potential.
- 7** Optimum CA/CT dimension will be influenced by type of loads carried and turning radius requirements.
- 8** The clear frame dimension given is the overall length of the hoist plus 5" for cab clearance and rear light bar mounting. Additional frame length may be necessary for accessories such as cab guard, tarper, exhaust system, etc.
- 9** PTO/Pump rotation as determined by transmission.
- 10** The hoist weight includes the base hoist with installation kit and cylinder oil.



An EFCO Company

SWAPLOADER[®]

"Hooked on Quality" U.S.A. LTD.

 YouTube www.youtube.com/swaploader

MADE IN USA 



1800 NE Broadway Ave., Des Moines, IA 50313

web: swaploader.com

email: sales@swaploader.net

toll free: 888.767.8000

phone: 515.266.3042