



The People You Know. The Products You Trust.



Schwarze GS6 Tempest™

6 Cubic Metre Regenerative Air Sweeper

*Sweeper shown with optional equipment

- Large Sweeping Width
- Choice of Cab Chassis
- Mirror Image Dual Steer & Dual Sweep
- 946 Litre Dust Suppression System



Quality	Performance	Public Safety	Value	Customer Support

800.879.7933

www.schwarze.com

Schwarze GS6 Tempest™

6 Cubic Metre Regenerative Air Sweeper



*Optional Equipment Shown

Increased hopper screen surface area through saw-tooth design.

Easy to use console with joystick broom control.



Shielded broom motor reduces entanglement of strings & twine.



Convenient and safe work platform.

MUST HAVE OPTIONS

INCREASED SURFACE CLEANSING

Add a High Pressure Front Spraybar.

PRESSURE WASHING OPTION

Add a high-pressure wash wand for easy cleanup and pressure washing.

GET NOTICED

A variety of arrowboard and lighting options.

ADD VERSATILITY

With a rear pit cleaning hose.

CONVENIENT MAINTENANCE

Add a safe work platform



VALUE

Schwarze is dedicated to satisfying its customers by providing the most advanced training for their specific needs. Its training programs are designed to help operators of all skill levels learn the best operating practices for their Schwarze equipment.



PERFORMANCE

There is a lot riding on creating solutions that are suited to the particular needs of different industry applications. Innovation often involves high technology, but doesn't always have to be. Some of Schwarze's best ideas have been simple, based on a clear and deep understanding of our customers' working lives.

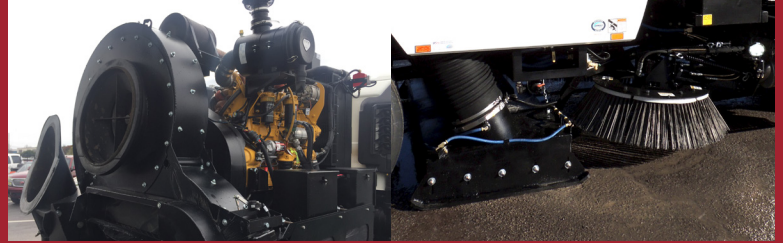

QUALITY

In a Schwarze product, end user concerns like fuel efficiency, serviceability, durability, purchase cost, service cost, etc. are all taken into account. They also consider the needs and strive for ease of use and application optimization. It should be obvious, because when it comes to cost of ownership, quality pays.



PUBLIC SAFETY

No other name speaks safety louder than Schwarze. Protecting operators, those around them, and minimizing our environmental impact are traditional values that continue to shape their product design philosophy.

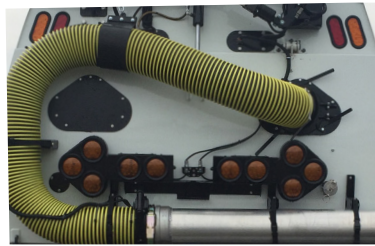

CUSTOMER SUPPORT

Being a Schwarze customer means having a complete set of services at your fingertips. Schwarze can offer you a long-term relationship, protect your revenue and provide a full range of customer solutions, delivered by passionate people. At Schwarze, they don't see effective service and support just as an added value to your purchase, but as an integral part of it.

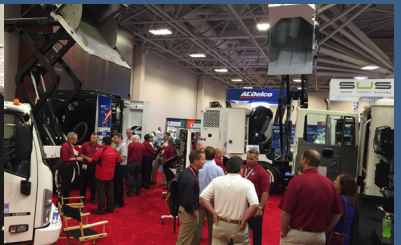
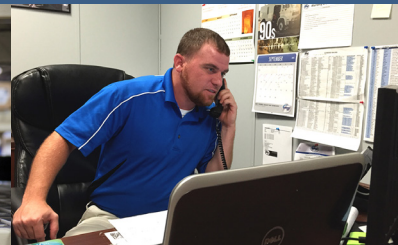

Also Available from Schwarze Industries, Inc:



Schwarze GS6 Tempest™

6 Cubic Metre Regenerative Air Sweeper

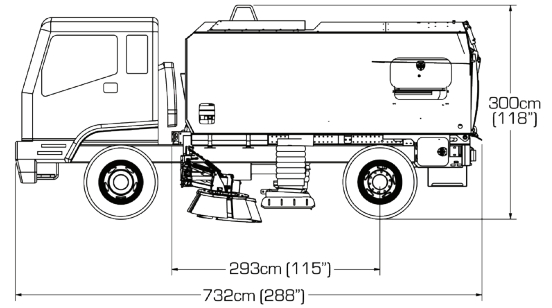
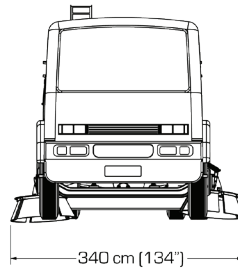

*TYPICAL MEASUREMENTS SHOWN, EXACT DIMENSIONS DEPENDING ON OPTIONS AND TRUCK MANUFACTURER

SWEEPING PATH

Pickup head only	2032 mm (80 in)
Pickup head and one gutter broom	2717 mm (107 in)
Pickup head and two gutter brooms	3404 mm (134 in)

DEBRIS HOPPER

Volumetric capacity	6 cu. m (7.8 cu. y)
Usable Capacity	4.97 cu. m (6.5 cu. y)
Dump angle	46°
Floor angle	3°
Lifting	Twin hydraulic cylinders
Hopper dump door	open/close/lock hydraulically
Inspection doors	1 on each side of hopper
Screens	Drop down design
Safety Prop	Dual steel tubes

CHASSIS

Mounts on various chassis to meet requirements

INSTRUMENTATION

Sweeper engine	Tachometer; hourmeter; voltmeter; temperature gauge
Sweeper	Load weight warning Hopper up indicator Hydraulic level indicator

STANDARD ENGINE

Model/type	4045HF285
Aspiration	Turbo-charged diesel
Manufacturer	John Deere
Displacement	4.5 l (275 cu. in)
Brake horsepower	86 kW (115 hp) @ 2400 rpm
Torque	430 nm (317 ft. lb.) @ 1500 rpm
Air cleaner	Dual element dry type w/centrifugal pre-cleaner & restriction indicator
Oil filter	Full-flow/spin-on
Safety shutdown	Three-point automatic
Throttle control	Electronic

DUST CONTROL SYSTEM

Pump	Run Dry Diaphragm
Capacity	946 l (250 gal)
Tank construction	Polyethylene filter; 50 mesh; cleanable
Fill diameter	63.5 mm (2.5 in)
Fill hose	7620 mm (25 ft)
Controls	Electric; in-cab
Nozzles	2 on each broom; 2 inside transition tube; 1 inside suction nozzle; 7 on hopper spray bar (optional)

BLOWER SYSTEM

Type	Closed-face radial
Drive	Direct via 5 single power belts
Construction	Hardox steel
Balance	1.5 g on 2 sides
Dimensions	832 mm x 127 mm (32.75 in x 5 in)
Housing lining	Bolt-in corded rubber
Mounting	Double sealed bearing spindle
Vacuum enhancer	For heavy/light material

PICKUP HEAD

Type	Dual chambered full-width blast orifice
Operating direction	Forward and reverse
Suspension	Adjustable spring balanced
Length	2032 mm (80 in)
Hose diameter	355.6 mm (14 in)
Hose construction	9.5 mm (3/8 in) wire-reinforced molded rubber
Head area	12903 cm ² (2000 sq. in)
Front flap	Hydraulic open and close

SIDE BROOMS

Type	Vertical steel digger
Location	Right; left; forward of pickup head
Diameter	990 mm (39 in)
Drive	Hydraulic
Suspension	Torque-sensing spring
Wear adjustment	Automatic
Pressure	Manual
Speed	Variable; non-reversing
Segments	4 each side; disposable
Tilt angle adjustment	In-cab controls

HYDRAULIC SYSTEM

Type	Gear type
Pump capacity	24.6 l/min @ 1800 rpm (6.9 gpm)
Drive	Direct gear
Maximum pressure	173 bar (2500 psi)
Reservoir	94 l (22.5 gal)
Filter	6 micron; spin on
Protection	Pressure relief valve
Controls	Electro-hydraulic

AUXILIARY HYDRAULIC SYSTEM

Type	Gear type; driven by electric motor
Function	Raise/lower hopper; open/close hopper door; raise/lower brooms and pickup head

ELECTRICAL SYSTEM

Voltage	12 v
Sweeper engine alternator	75 amp

OPERATOR CONVENIENCE

Access platform behind cab
Low pressure wash-down

PAINT

One coat of sealer/primer and two coats of Dupont imron elite polyurethane in standard white color

Note: Design and specifications subject to change without notice.

Affiliates:



© 2021 Schwarze Industries
1055 Jordan Road
Huntsville, AL 35811
800.879.7933
An Alamo-Group Company

