



The People You Know. The Products You Trust.



A4 Storm™

4.5 Cubic Yard Regenerative Air Street Sweeper

*Sweeper shown with optional equipment



- High Performance Sweeping Head
- Up to 197 Gallon Water Capacity
- 77" Dump Height
- No CDL Required

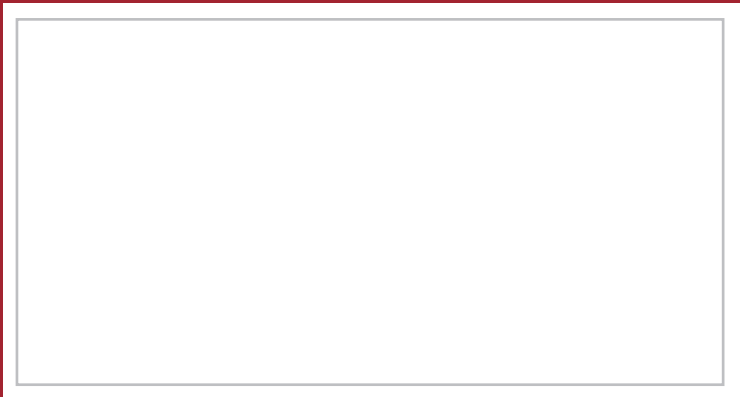

Quality	Performance	Public Safety	Value	Customer Support

800.879.7933

www.schwarze.com

↑ 77" Dump Height

A4 Storm™ 4.5 Cubic Yard Regenerative Street Sweeper



4.5 Cubic Yard Hopper
Separate Door for Intake
Screen Cleanout

Hardox Steel Fan
Balanced to 1.5 Grams
EPA Tier 4 Final Engine

Built-In Strobes
All LED Lighting
Backup Alarm
Backup Camera

Onboard Diagnostics
Color Coded
Switches

Large Toolboxes

◀◀ Sweeps-In-Reverse

High Performance
Sweeping Head Quick Disconnect Tubes



MADE IN THE USA

*Optional Equipment Shown, Blue Frame Special Order

Redesigned high performance sweeping head

Easy to use color coded switches with Onboard Diagnostics

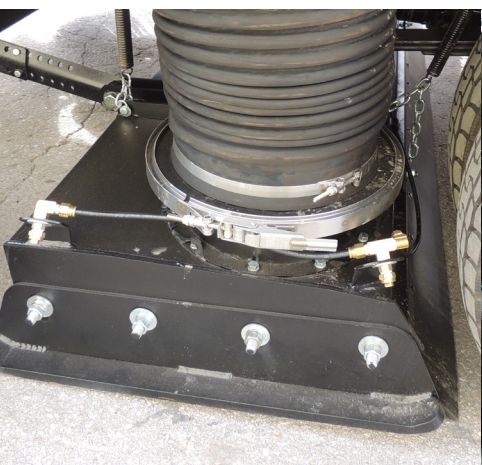

MUST HAVE OPTIONS

ADDITIONAL WATER
Add an additional 66 gallon for 196 gallon total

LIFETIME HOPPER
Add a hopper with lifetime warranty

EXTENDED REACH
Add broom tilt and Gutterbroom Extension Override (GEO™)

EXTENDED REACH
Add a hand hose for hard to get to reach applications

Quick release clamps for easy rotation and replacement of hoses.

Large corrosion free toolboxes for 35 square feet of storage.

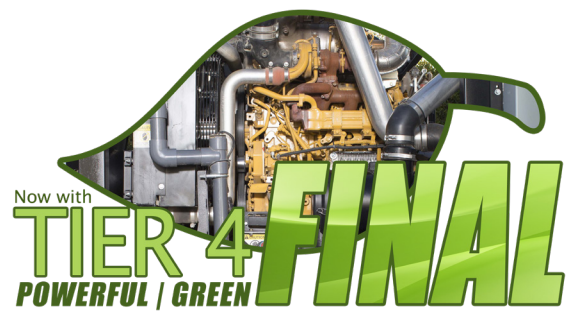

VALUE

We are dedicated to satisfying our customers by providing the most advanced training for their specific needs. Our training programs are designed to help operators of all skill levels learn the best operating practices for their Schwarze equipment.



PERFORMANCE

There is a lot riding on creating solutions that are suited to the particular needs of different industry applications. Innovation often involves high technology, but doesn't always have to be. Some of our best ideas have been simple, based on a clear and deep understanding of our customers' working lives.



QUALITY

In a Schwarze product, end user concerns like fuel efficiency, serviceability, durability, purchase cost, service cost, etc. are all taken into account. We also consider the needs and strive for ease of use and application optimization. It should be obvious, because when it comes to cost of ownership, quality pays.

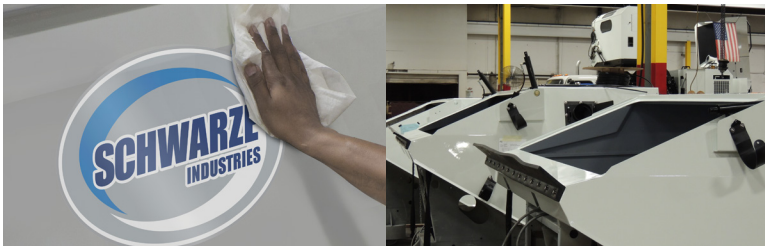

PUBLIC SAFETY

No other name speaks safety louder than Schwarze. Protecting operators, those around them, and minimizing our environmental impact are traditional values that continue to shape our product design philosophy.



CUSTOMER SUPPORT

Being a Schwarze customer means having a complete set of services at your fingertips. Schwarze can offer you a long-term relationship, protect your revenue and provide a full range of customer solutions, delivered by passionate people. At Schwarze, we don't see effective service and support just as an added value to your purchase, but as an integral part of it.



Also Available from Schwarze Industries, Inc:



A4 Storm

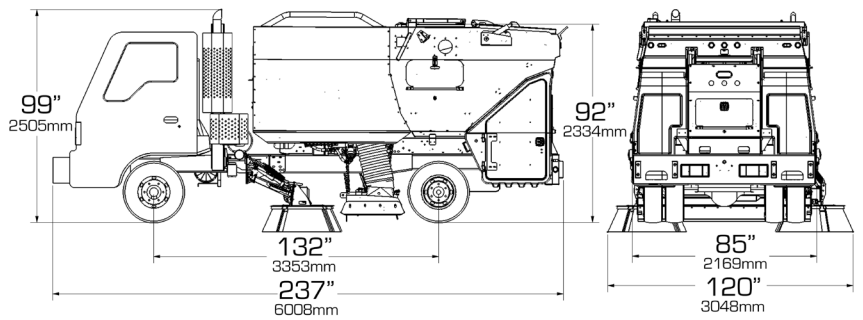

*TYPICAL MEASUREMENTS SHOWN, EXACT DIMENSIONS DEPENDING ON OPTIONS AND TRUCK MANUFACTURER

SWEEPING PATH

Pickup head only	80 in (2,032 mm)
Pickup head and one gutter broom	100 in (2,540 mm)
Pickup head and two gutter brooms	120 in (3,048 mm)

CHASSIS

Model / type	4HK1-TC / 4 cycle
Manufacturer	Isuzu
Number of Cylinders	4
Displacement	317 cu in (5.26 L)
Horsepower	215 @ 2500 rpm
Torque	452 lb-ft @ 1800 rpm
Fuel	Diesel
Air filter	Dry type; heavy duty
Standard GVWR	14,500 lb (6,577 kg)
Optional GVWR	17,950 lb (8,142 kg)
Transmission	A465; 6 speed automatic
Tires	(6) Tubeless steel-belted radials 225/70 R 19.5
Wheels	Steel construction
Steering	Integral power;
Brake	Vacuum/hydraulics with ABS

STANDARD ENGINE

Type	QSF2.8 diesel Tier 4F
Manufacturer	Cummins
Displacement	171 cu in (2.8 L)
Brake horsepower	74 @ 2500 rpm
Cooling system	Liquid-cooled
Air cleaner	Dual element, dry-type with restriction indicator; centrifugal pre-cleaner
Safety shutdown	Three-point automatic
Throttle control	Electronic
Instrumentation	Digital display Tachometer; hourmeter; voltmeter; temperature; oil pressure.
Control console	Tilting and rotating

ELECTRICAL SYSTEM

Voltage	12 volt
Battery	2 @ 750 cca each
Alternator	120 amp
Circuit breakers	Resettable type

DUST CONTROL SYSTEM

Type	Electric diaphragm, run dry capable
Capacity	130 gal (492 L) standard optional to 196 gal (684 L)
Tank construction	Polyethylene
Filter	50 mesh, cleanable
Fill diameter	2.5 in (63.5 mm)
Fill hose	25 ft (7620 mm)
Controls	Electric; in-cab
Nozzles	2 on each broom; 4 around suction head; 4 inside hopper

FAN SYSTEM

Type	Closed-face radial
Drive	Direct via 3V 5 groove banded power belt
Construction	Hardox Steel
Balance	1.5 grams on 2 sides
Diameter	30 in (762 mm)
Housing lining	Bolt-in corded rubber
Mounting	2 sealed bearings
Vacuum enhancer	For heavy/light material

SWEEPING HEAD

Type	Dual chambered full-width Adjustable blast orifice
Operating direction	Forward and reverse
Suspension	Adjustable spring balanced
Length	80 in (2,032 mm)
Hoses Diameter	12 in (305 mm)
Hose Construction	3/8 in (9.5 mm) wire-reinforced molded rubber with quick disconnect clamps
Controls	Hydraulic raise and lower
Skids	Double wide tungsten carbide
Construction	Bolt in replaceable steel transitions.

PAINT

One coat of sealer/primer and two coats of in standard white color.	
Paint	White; Sherwin Williams Genesis G2 #100268977

SIDE BROOMS

Type	Vertical steel digger
Location	Right, Left, forward of pickup head
Diameter	39 in (991 mm)
Drive	Hydraulic torque motor
Wear adjustment	Automatic
Pressure	Manual
Speed	Variable, non-reversing
Segments	4 each side, disposable; tempered steel wire filled
Tilt adjustment	Manual with optional in-cab controls

DEBRIS HOPPER

Volumetric Capacity	4.5 cu y (3.4 cu m)
Construction	10 gauge
Type of Dumping	Hydraulic
Inspection Doors	1 on each side of hopper
Controls	Electric; in cab
Dumping Height	77 in (1956 mm)
Dumping Tilt Angle	88 degrees
Interior Coating	Durable coating
Exterior Coating	Sealer/primer; Polyurethane

HYDRAULIC SYSTEM

Type	Fixed displacement gear
Drive	Direct gear
Maximum pressure	2500 psi (173 bar)
Reservoir	16 gal (60.6 L)
Filter	10 micron, spin on
Protection	Pressure relief valve
Controls	Electro-hydraulic
Filter	80 mesh

Design and specifications subject to change without notice.

*Ask us about our optional:



Sourcewell

Awarded Contract

Contract # 093021-SWZ

HGACBUY
THE SMART PURCHASING SOLUTION



© 2022 Schwarze Industries
1055 Jordan Road
Huntsville, AL 35811
800.879.7933
An Alamo-Group Company