LH 30 - LH 35 Industry

LIEBHERR

Material handling machines

Generation

6

Operating weight

58,400–70,300 lb*

Engine

188 HP / 140 kW

Stage V

Stage IIIA (compliant)

Tier 4 Final

* Without attachment



Performance

Power plus speed –
Redefined performance

Economy

Good Investment –
Savings for long-term

Reliability

Durability and sustainability –
Quality down to the last detail

Comfort

Perfection at a glance –
When technology is comfortable

Maintainability

Efficiency bonus –
Even with maintenance and service



* Without attachment



LH 30 M Industry Litronic

Operating weight
58,400–64,200 lb *

Engine
188 HP / 140 kW
Stage V
Stage IIIA (compliant)
Tier 4 Final

LH 35 M Industry Litronic

Operating weight
67,700–70,300 lb *

Engine
188 HP / 140 kW
Stage V
Stage IIIA (compliant)
Tier 4 Final

LH 30 C Industry Litronic

Operating weight
59,700–66,600 lb *

Engine
188 HP / 140 kW
Stage V
Stage IIIA (compliant)
Tier 4 Final

Performance



Power plus speed – Redefined performance

Liebherr has been designing and manufacturing market leading material handling machines for over 60 years. The generation of Liebherr handlers, the LH 30 and LH 35 are high performance yet economical machines specially designed for use in scrap recycling, in timber yards and also for bulk handling.

Maximum handling capacity

High engine performance

The optimized design of the 140 kW engine supplies a high torque output for fast and strong movements. Load peaks are cleverly compensated for to ensure that maximum torque is available at all times for highest handling capacity.

High swing torque

The separate hydraulic pump in the closed slewing circuit only supplies hydraulic fluid to the swing mechanism. The maximum delivery volume is thus available at any time for turning the uppercarriage for fast and dynamic rotational movements.

Captivating dynamics

The combination of 140 kW of engine output and high pump delivery volume guarantees maximum acceleration and speed of working motions.

Precision operation

Intelligent electronics

The elaborate machine controls guarantee that the hydraulics are optimally configured for the task at hand. Here, the load sensing control ensures that the flow delivered by the pump is optimally distributed when movements overlap. Speed and power are available whenever they are needed.

Sensitive hydraulics

The optimal harmonisation between the engine and the control valve allows a fast and direct response from the hydraulics to the input command. This is controlled proportionally to enable smooth and gentle movements to be executed when the joystick is moved.

Firm and stable positioning

An essential prerequisite for precise working and maximum handling capacity is the firm and stable positioning of the machine. The design of the Liebherr undercarriage optimizes the way forces are induced on components to minimise stress and guarantee maximum stability and durability.



Liebherr diesel engine compliant with Tier 4 Final

- Powerful, robust and reliable
- Maximum torque even at low speeds to ensure fast movements with low fuel consumption
- Common-Rail injection system for maximum efficiency
- Emissions treatment with Liebherr SCR technology at stage V

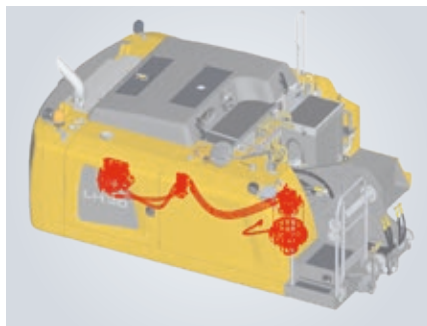

Closed slewing circuit

- High torque for maximum acceleration and fast rotary movements
- Integrated speed sensor for controlling and monitoring braking movement for greater safety
- Greater fuel efficiency thanks to intelligent energy management in the closed system



Travel motor

- Powerful, robust, reliable and quiet
- Better performance even on uphill grades due to electrical swivel angle adjustment for more torque, maximum acceleration and more driving power
- Fuel efficiency at maximum speed due to optimal adjustment of speed and delivery volume

Economy



Good investment – Savings for long-term

Liebherr material handling machines combine high productivity with excellent economy – all as standard. Liebherr manages to achieve this difficult goal through sophisticated engine technology from its own production and improved demand-controlled hydraulics.

Fuel efficiency

Lower engine rpm

A low engine speed of 1,700 rpm and high torque values allow the operating point of the machine to be quickly achieved. This gives excellent fuel efficiency and high handling performance.

Engine idling and engine shut-down

The standard automatic idling function reduces the engine speed to idle as soon as the operator takes his hand from the joystick so that no hydraulic function is activated. Proximity sensors in the joystick levers restore the original engine speed as soon as the operator's hand is moved towards the lever again. This ensures that the set engine speed is available immediately. The result is a combination of fuel saving and reduced noise levels. Operating costs can be reduced even further with the optional automatic engine shut-down function.

Closed hydraulic circuit for the swing mechanism

The closed slewing circuit feeds the braking energy back into the system when the uppercarriage is braked. Here, new standards are set in terms of efficiency and economy. Simple yet effective.

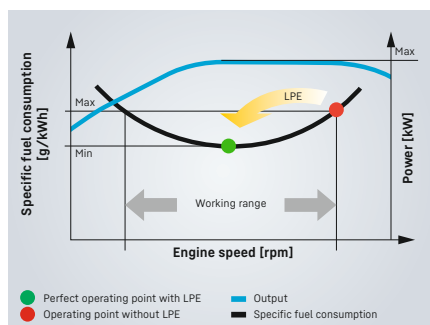

Low fuel consumption thanks to intelligent machine control

- Liebherr-Power Efficiency (LPE) optimizes the interaction of the drive components in terms of efficiency
- LPE enables machine operation in the area of the lowest specific fuel use for less consumption and greater efficiency with the same performance

Increased productivity

Attachments and quick coupling systems

Liebherr offers a wide selection of attachments for every application to increase the productivity of its material handling machines. In addition the material handlers can be fitted with a Liebherr quick coupling system which increase the productivity of the machine by up to 30%. The matching attachment and quick coupling system combined with the outstanding dynamics of a Liebherr handler ensures highest handling capacity and maximum productivity.

Efficient management

LiDAT, Liebherr's own data transmission and positioning system, facilitates efficient management, monitoring and control of the entire fleet park in terms of machinery data recording, data analysis, fleet park management and service. All of the important machinery data can be viewed at any time in a web browser. LiDAT offers you comprehensive work deployment documentation, greater availability thanks to shorter downtimes, faster support from the manufacturer, quicker detection of strain/overload and subsequently a longer service life of the machine as well as greater planning efficiency in your company. This service includes 1 year of use without charge as standard for the material handlers LH 30 and LH 35.



Liebherr-attachments

- Robust and service-friendly slewing drive, can be turned 360°
- Optimum filling and clamping performance for effective material handling
- Finite element method (FEM) optimized for a perfect relationship between grapple weight, volume and a very long service life



Eco-Mode

- Reducing the engine speed by pressing a button
- Lower fuel consumption with unchanged high performance
- Economical and environmentally friendly working guaranteed
- Ideal for light to medium operations

Reliability



Durability and sustainability – Quality down to the last detail

Every day Liebherr material handlers show their qualities in a range of industrial applications all over the world. Years of experience, continuous development and the latest technologies provide maximum safety in use. Their robust, compact design and the use of components produced in-house ensure that the LH 30 and LH 35 are designed for a long service life.

More safety

Pipe fracture safety valves

The standard pipe fracture safety valves on the stick and hoist cylinders prevents the attachments from dropping in an unregulated way and ensure maximum safety during every operation.

Working range limiters

For operations in which the working range should be limited, the material handling machines can be equipped optional with a working range limitation feature. Hereby all types of dimensions can be set: height, depth, width and proximity. Collisions and resulting component damage can thus be avoided.

Overload warning device and load torque limitation

The acoustic and visual overload warning system continuously tells the operator about the current load situation of the machine. Furthermore, load torque limitation automatically regulates the speed of the working hydraulics to allow the maximum load bearing capacity to be approached safely. In the event of an overload, the functions which could cause the machine to topple are disabled. Only movements back to the safe working range are then possible.

High machine availability

Quality and competence

Our experience, understanding of customer needs and the technical implementation of these findings guarantee the success of the product. For decades, Liebherr has been inspirational with its depth of production and system solutions. Key components such as the diesel engine, electronic components, slewing ring, swivelling drive and hydraulic cylinders are developed and produced by Liebherr itself. The great depth of in-house manufacturing guarantees maximum quality and ensures that components are optimally configured to each other.

Robust design

All steel components are designed and manufactured by Liebherr itself. High-strength steel plates configured for the toughest of requirements result in high torsional stiffness and optimum absorption of forces induced for a longer service life.

Intelligent self diagnostics

The clever control electronics permanently monitor the vital functions of the machine to guarantee a high level of machine availability. Components which are critical for safety are designed with redundancy to guarantee maximum reliability.



QPDM – Quality and process data management

- QPDM allows production data to be logged, documented and evaluated
- Automation of documentation and test specifications
- Ability to handle large quantities with maintain uniform high quality



Dust-intensive jobs

- Large-dimension radiator with large mesh for optimum cooling performance even in very dusty places
- Sealed engine compartment prevent dust penetration
- Reversible fan reduces the rate at which the engine and radiator become clogged and guarantee good machine availability
- Folding air conditioning condenser for quicker and easier cleaning



Attachment

- Components enhanced using FEM for maximum service life even if subjected to heavy lateral stresses during demanding tasks
- Cables routed internally to protect them from damage
- High load capacities with long reaches
- Reaches over 66 ft

Comfort



Perfection at a glance – When technology is comfortable

The Liebherr deluxe cab is spacious, has an ergonomic design and is very quiet. This ensures that the operator remains intent and fully concentrated throughout the working day and enables him to deliver a constantly high performance.

Deluxe cab

Ergonomic design

The modern cab design provides excellent conditions for healthy, concentrated and productive work in maximum comfort. The colour touchscreen display, the controls and operator's seat Comfort are all coordinated to form a perfect ergonomic unit. In addition the ergonomic joysticks allow the machine operation to be both pleasant and precise.

Excellent all-round vision

The large areas of glass, different versions of cab elevations and the rear and side area monitoring systems provide the operator with an excellent view of his working area and the zone around the machine. This perfect view enhances the operator's safety and ensures that he can handle the machine safely at all times.

Low noise levels

The use of viscoelastic mounts, good insulation and low-noise diesel engines from Liebherr minimizes noise emissions and vibrations. This means that the material handlers LH 30 and LH 35 have low noise to preserve people and the environment.

Comfortable operation

Proportional control

Precision and fine control of the material handling machine are especially important in applications such as waste separation or scrap recycling. Thanks to the standard proportional control, even such demanding operations can be mastered in style.

Steering and stabilizer on joystick

The standard joystick steering gives the operator an additional comfort boost. The steering movement can be conveniently executed using the joystick, eliminating the need to reposition during the work cycle. Abandoning the steering wheel in favour of joystick steering provides additional legroom and a clear view of the working area. A standard feature is the control of the outriggers with the joystick for more comfort and an increased productivity of the machine.

Colour touchscreen display and operation unit

The 9" colour touchscreen display is intuitive in its operation and provides continuous information about all important operating data. The shortcut keys can be individually assigned and are selected quickly and easily with the menu strip.



Safe access

- Foldable arm console for a safe and comfortable access
- Wide, non-slip steps and ergonomically positioned handles for an easy and safe access
- All access systems are designed to national guidelines and statutory regulations

Operator's seat comfort with adjustable armrests

- Greater seating comfort due to variable damper hardness, lockable horizontal suspension, pneumatic lumbar support, seat heating and passive seat air conditioning for concentrated working
- Individual adjustment options for armrests, seat cushion depth, seat angle and head restraint for healthful working

Joystick with proportional control

- Good functionality with streamlined, ergonomic design
- 4-way mini joystick can be used to control all operations e.g. steering, outriggers and attachments etc.
- Joysticks – each with two buttons and a rocker switch – also increase the number of functions and thanks to the new design maximum reliability is guaranteed

Maintainability



Efficiency bonus – Even with maintenance and service

The Liebherr LH 30 and LH 35 material handling machines are powerful, robust, precise and efficient. They also feature integral maintenance benefits as a result of their service-based design. All maintenance work for Liebherr material handlers can be carried out quickly, easily and safely. This minimizes the machine's maintenance costs and downtime.

Elaborate maintenance concept

Service-based machine design

The service-based machine design guarantees short servicing times, thus minimising maintenance costs due to the time it saves. All the maintenance points are easily accessible from the ground and easy to reach due to the large, wide-opening service doors. The enhanced service concept places the maintenance points close to each other and reduces their number to a minimum. This means that service work can be completed even more quickly and efficiently.

Integral maintenance benefits

Maintenance work helps to keep the machine fully functional. However this kind of work leads to machine downtimes which have to be minimized. With change intervals of up to 2,000 hours for engine oil and up to 8,000 hours for hydraulic oil, Liebherr has significantly reduced the amount of maintenance and increased the productivity of the material handlers. In addition, central lubrication systems minimize daily maintenance.

Your competent service partner

Remanufacturing

The Liebherr remanufacturing program offers cost-effective reconditioning of components to the highest quality standards. Various reconditioning levels are available: Replacement components, general overhaul or repair. The customer receives components with original part quality at a reduced cost.

Competent advice and service

Competent advice is given at Liebherr. Experienced specialists provide decision guidance for your specific requirements: application-oriented sales support, service agreements, value-priced repair alternatives, original parts management, as well as remote data transmission for machine planning and fleet management.

Fast spare parts service

The Liebherr spare parts service provides 24-hour delivery and is therefore available to our dealers around the clock. Thanks to the electronic spare parts catalogue, the parts can be selected and ordered quickly and reliably using the Liebherr online portal. Your order can be tracked at any time using the online tracking system.



Lubrication as it works

- Fully automatic central lubrication system for uppercarriage and equipment
- Can be extended as an option to the connection link, quick coupler and attachment
- Fully automatic central lubrication system for the undercarriage available as an option
- Lubricates without interrupting work to ensure better productivity and a long component service life



Excellent service access

- Large, wide-opening service doors
- Engine oil, fuel, air and cab air filters are easily and safely accessible from the ground
- The oil level in the hydraulic tank can be checked from the cab
- Short service times for more productivity



Rapid spare parts service

- 24-hour delivery: Spare parts service is available for our dealers around the clock
- Electronic spare parts catalogue: Fast and reliable selection and ordering via the Liebherr online portal
- With online tracking, the current processing status of your order can be viewed at any time

Material handling machines overview

Equipment

- High load capacities and long reaches thanks to optimized kinematic properties and robust construction for greater handling performance
- Ingenious routing of hydraulic hoses optimizes the oil flow and minimises power losses for maximum energy efficiency
- Pipe fracture safety valves on hoist and stick cylinders and retract stick shut-off for maximum safety during every application
- Quick coupling systems and attachments made by Liebherr for maximum machine capacity utilization and greater handling performance

Operator's cab

- Joystick steering without steering column as standard for convenient operation, greater legroom and clear view of the working area
- Less strain on the operator, workers and reduced environmental pollution due to lower noise emissions
- Optimum visibility thanks to large glass surfaces and standard rear and side area monitoring with camera
- Proportional control is standard with 4-way minijoystick for greater precision, high precision control and functions





Uppercarriage

- Greater fuel efficiency thanks to the latest engine technology with intelligent machine control
- 140 kW engine output and a high pump flow for fast work cycles, convincing dynamics and maximum handling performance
- Reversible fan and large-meshed cooler as a reliable, sealed unit for high machine availability
- Reduction in operating costs thanks to built-in maintenance advantages and optimum service accessibility

Undercarriage

- Optimized hydraulics with closed slewing mechanism circuit for greater fuel efficiency and faster work cycles
- Maximum acceleration and high drawbar pull thanks to the motor for greater travelling performance
- Load-holding valves fitted as standard on all support cylinders for maximum stability in every application
- Less downtime thanks to maintenance-free support cylinders

The perfect solution for every application

Attachments

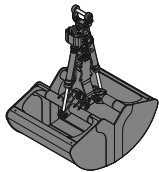

Shells for loose material

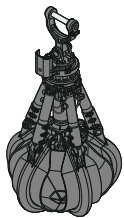

Multi-tine grab

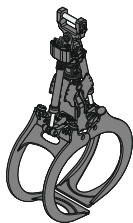

Wood grab

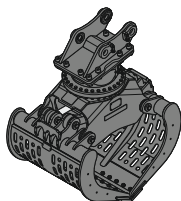

Sorting grab

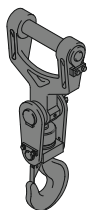

Load hook

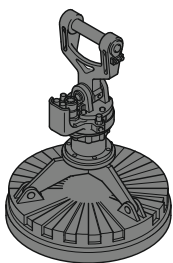

Magnet devices

Sticks

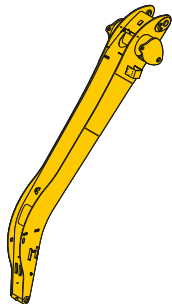

Angled stick

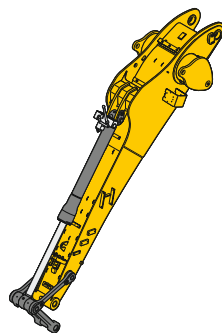

Lightweight stick

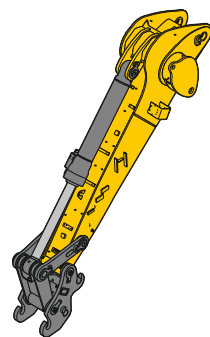

Stick with tipping kinematics

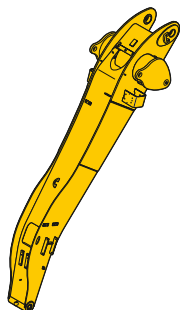

Straight stick

Booms

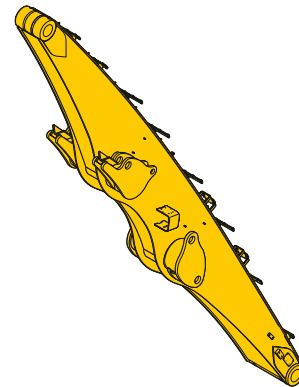

Straight boom

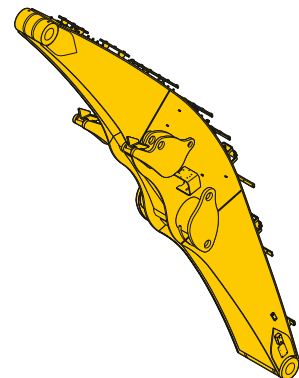

Angled boom

Cab elevations

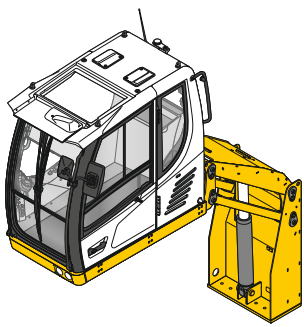

Hydraulic cab elevation



30° tilt function

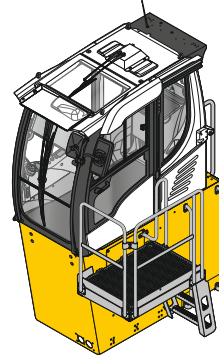

Rigid cab elevation

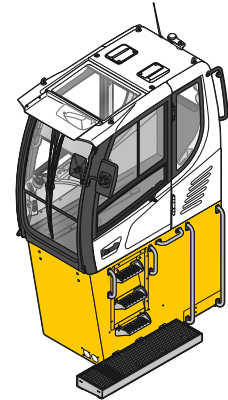

Uppercarriage

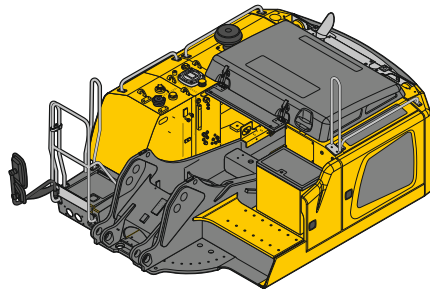

Undercarriage

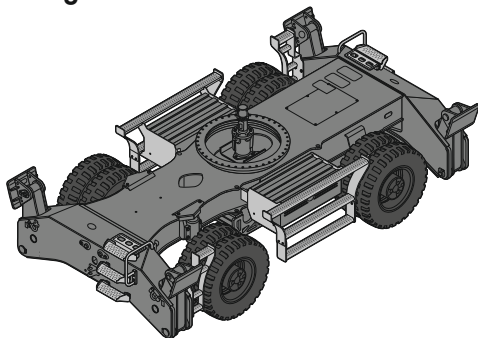

Mobile

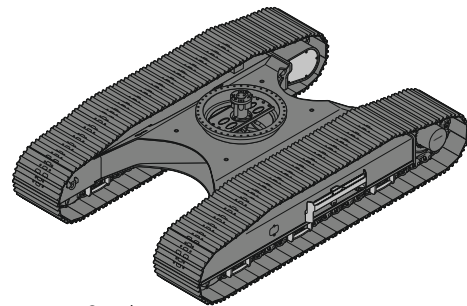

Crawler

Technical data



Diesel engine

Rating	
per SAE J1349	188 HP (140 kW) at 1,700 rpm
per ISO 9249	190 HP (140 kW) at 1,700 rpm
Model	Liebherr D934
Type	4 cylinder in-line
Bore / Stroke	4.8 / 5.9 in
Displacement	427.17 in ³
Engine operation	4-stroke diesel Common-Rail Turbo-charged and after-cooled Reduced emissions
Air cleaner	Dry-type air cleaner with pre-cleaner, primary and safety elements
Engine idling	Sensor controlled
Electrical system	
Voltage	24 V
Batteries	2 x 135Ah / 12V
Alternator	Three-phase current 28V / 140A
Stage V	
Harmful emissions values	According to regulation (EU) 2016/1628
Emission control	Liebherr-SCRFilter technology
Fuel tank	85 gal
Urea tank	12 gal
Stage IIIA (compliant)	
Harmful emissions values	In accordance with ECE-R.96 Power Band H
Fuel tank	85 gal
Tier 4 Final	
Harmful emissions values	In accordance with 40CFR1039 (EPA) / 13CCR (CARB)
Emission control	Liebherr-SCR technology
Fuel tank	85 gal
Urea tank	12 gal



Cooling system

Diesel engine	Water-cooled Compact cooling system consisting cooling unit for water, hydraulic oil and charge air with stepless thermostatically controlled fan
----------------------	------------------------------------------------------------------------------------------------------------------------------------------------------



Hydraulic controls

Power distribution	Via control valves with integrated safety valves, simultaneous actuation of chassis and equipment. Swing drive in separate closed circuit
Servo circuit	
Equipment and swing	With hydraulic pilot control and proportional joystick levers
Chassis	
Mobile	Electro-proportional via foot pedal
Crawler	With hydraulic proportionally functioning foot pedals or adjusted with plugable levers
Additional functions	
Proportional control	Via switch or electro-proportional foot pedals Proportionally acting transmitters on the joysticks for additional hydraulic functions



Hydraulic system

Hydraulic pump	
For equipment and travel drive	2 Liebherr axial piston variable displacement pumps (double construction)
Max. flow	2 x 61 gpm
Max. pressure	5,076 psi
For swing drive	Reversible axial piston variable displacement pump, closed-loop circuit
Max. flow	37 gpm
Max. pressure	6,092 psi
Hydraulic pump regulation and control	Liebherr-Synchron-Comfort-system (LSC) with electronic engine speed sensing regulation, pressure and flow compensation
Hydraulic tank	46 gal
Hydraulic system Filtration	114 gal
	1 main return filter with integrated partial micro filtration (5 µm)
MODE selection	Adjustment of engine and hydraulic performance via a mode pre-selector to match application, e.g. for especially economical and environmentally friendly operation or for maximum material handling and heavy-duty jobs
S (Sensitive)	Mode for precision work and lifting through very sensitive movements
E (Eco)	Mode for especially economical and environmentally friendly operation
P (Power)	Mode for high performance with low fuel consumption
P+ (Power-Plus)	Mode for highest performance and for very heavy duty applications, suitable for continuous operation
Engine speed and performance setting	Stepless alignment of engine output and hydraulic power via engine speed
Option	Tool Control: 20 pre-adjustable pump flows and pressures for add-on attachments



Swing drive

Drive	Liebherr axial piston motor in a closed system, Liebherr planetary reduction gear
Swing ring	Liebherr, sealed race ball bearing swing ring, internal teeth
Swing speed	0-9.7 rpm stepless
Swing torque	52,367 lbf ft
Holding brake	Wet multi-disc (spring applied, pressure released)
Operation holding brake (Option)	Slewing gear brake Comfort



Cab

Cab	TOPS safety cab structure (tip-over protection) with individual windscreens or featuring a slide-in subpart under the ceiling, work headlights integrated in the ceiling, a door with a sliding window (can be opened on both sides), large stowing and depositing possibilities, shock-absorbing suspension, sound damping insulating, tinted laminated safety glass, separate shades for the sunroof window and windscreen
Operator's seat Comfort	Air cushioned operator's seat with 3D-adjustable armrests, headrest, lap belt, seat heater, adjustable seat cushion inclination and length, lockable horizontal suspension, automatic weight adjustment, adjustable suspension stiffness, pneumatic lumbar vertebrae support and passive seat climatization with active coal
Operator's seat Premium (Option)	In addition to operator's seat comfort: active electronic weight adjustment (automatic readjustment), pneumatic low frequency suspension and active seat climatization with active coal and ventilator
Arm consoles	Joysticks with control consoles and swivel seat, folding left control console
Operation and displays	Large high-resolution operating unit, self-explanatory, color display with touchscreen, video-compatible, numerous setting, control and monitoring options, e.g. air conditioning control, fuel consumption, machine and attachment parameters
Air-conditioning	Automatic air-conditioning, recirculated air function, fast de-icing and demisting at the press of a button, air vents can be operated via a menu; recirculated air and fresh air filters can be easily replaced and are accessible from the outside; heating-cooling unit, designed for extreme outside temperatures, sensors for solar radiation, inside and outside temperatures



Equipment

Type	High-strength steel plates at highly-stressed points for the toughest requirements. Complex and stable mountings of equipment and cylinders
Hydraulic cylinders	Liebherr cylinders with special sealing and guide system and, depending on cylinder type, shock absorption
Bearings	Sealed, low maintenance



Undercarriage

Mobile	
Drive	Oversized two speed power shift transmission with additional creeper speed, Liebherr axial piston motor with functional brake valve on both sides
Travel speed	
Joystick steering	0-2.2 mph stepless (creeper speed + transmission stage 1) 0-4.3 mph stepless (transmission stage 1) 0-7.5 mph stepless (creeper speed + transmission stage 2) 0-7.5 mph stepless (transmission stage 2)
Wheel steering (Option)	0- 2.2 mph stepless (creeper speed + transmission stage 1) 0- 4.3 mph stepless (transmission stage 1) 0- 8.1 mph stepless (creeper speed + transmission stage 2) 0-12.4 mph stepless (transmission stage 2)
Driving operation	Automotive driving using accelerator pedal, cruise control function: storage of variable accelerator pedal positions
Axles	88,185 lb / 132,277 lb drive axles (LH 30 M / LH 35 M); manual or automatic hydraulically controlled front axle oscillation lock
Option	Four wheel steering (LH 35 M)
Service brake	Two circuit travel brake system with accumulator; wet and backlash-free disc brake
Holding brake	Wet multi-disc (spring applied, pressure released)
Stabilization	4 point outriggers
Option	Dozer blade, at the front, for 4 point outriggers
Crawler	
Versions	LC, EW
Drive	Liebherr compact planetary reduction gear with Liebherr axial piston motor per side of undercarriage
Travel speed	0-1.9 mph stepless (creeper speed) LC undercarriage 0-1.9 mph stepless (creeper speed) EW undercarriage 0-2.9 mph stepless LC undercarriage 0-2.5 mph stepless EW undercarriage
Brake	Functional brake valves on both sides
Holding brake	Wet multi-disc (spring applied, pressure released)
Track pads	Triple grouser
LC (Option)	Rubber



Complete machine

Lubrication	Liebherr central lubrication system for uppercarriage and equipment, automatically
Mobile (Option)	Liebherr central lubrication system for undercarriage, automatically
Steps system	Safe and durable access system with anti-slip steps; main components hot-galvanized
Noise emission	
ISO 6396 (Stage V)	70 dB(A) = L _{PA} (inside cab)
2000/14/EC (Stage V)	103 dB(A) = L _{WA} (surround noise)
ISO 6396 (Stage IIIA compliant)	71 dB(A) = L _{PA} (inside cab)
2000/14/EC (Stage IIIA compliant)	103 dB(A) = L _{WA} (surround noise)
ISO 6396 (Tier 4 Final)	71 dB(A) = L _{PA} (inside cab)
2000/14/EC (Tier 4 Final)	103 dB(A) = L _{WA} (surround noise)

LH 30 M – Dimensions

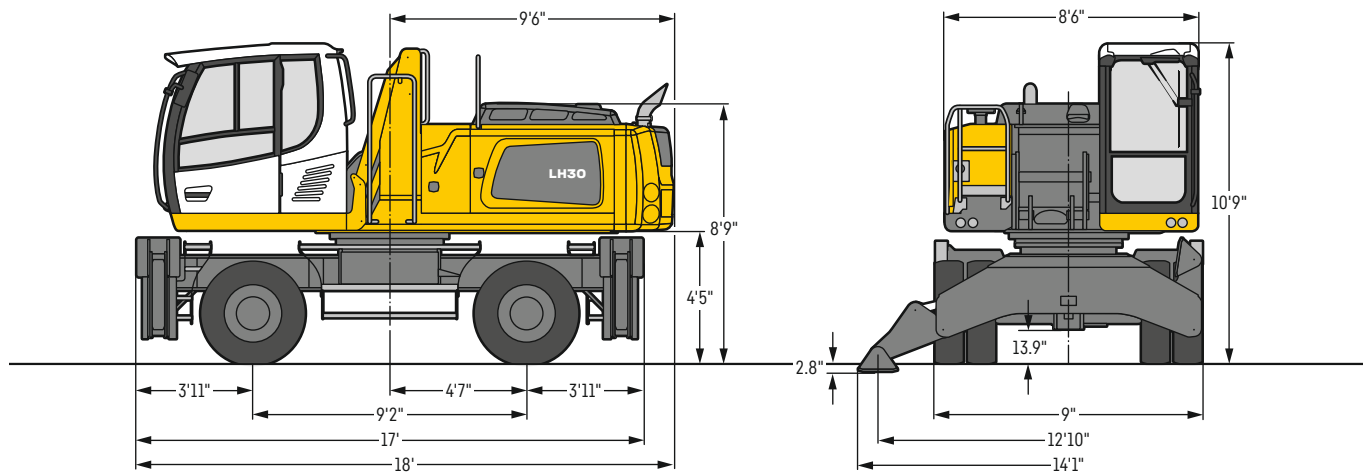

* 9'11" with heavy counterweight

LH 30 M – Choice of cab elevation

**Cab elevation LFC 120
(rigid elevation)**

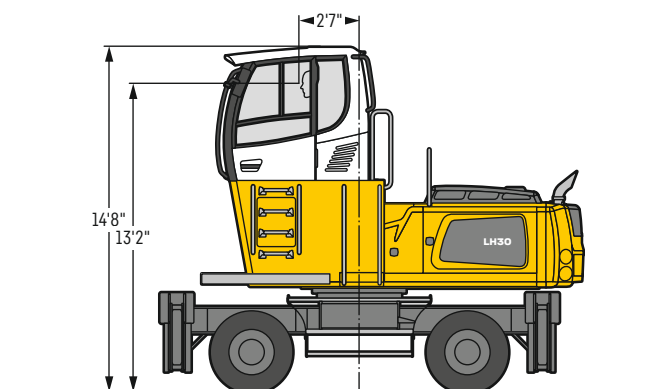

A rigid cab elevation has a fixed eye level height. For a lower transport height, the shell of the cab can be removed and replaced by a transport device. The dimension 14'8" is in this machine design for all rigid cab elevations 11'9".

**Cab elevation LHC 255
(hydraulic elevation)**

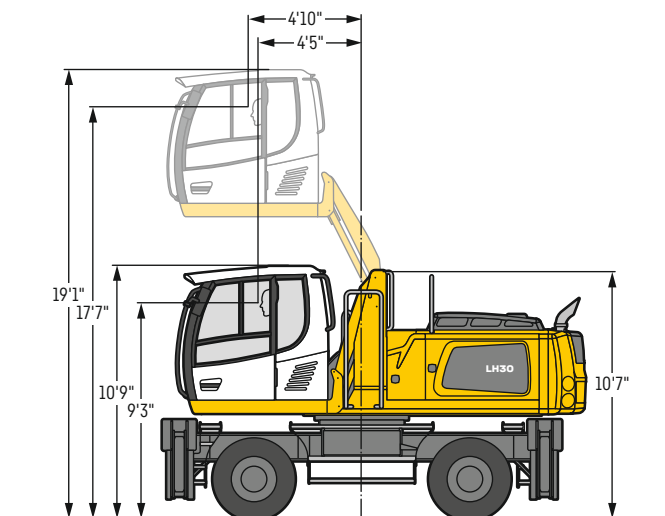

The hydraulically adjustable cab allows the driver, that he can choose his field of view freely and at any time within the stroke.

Tires 10.00-20

LH 35 M – Dimensions

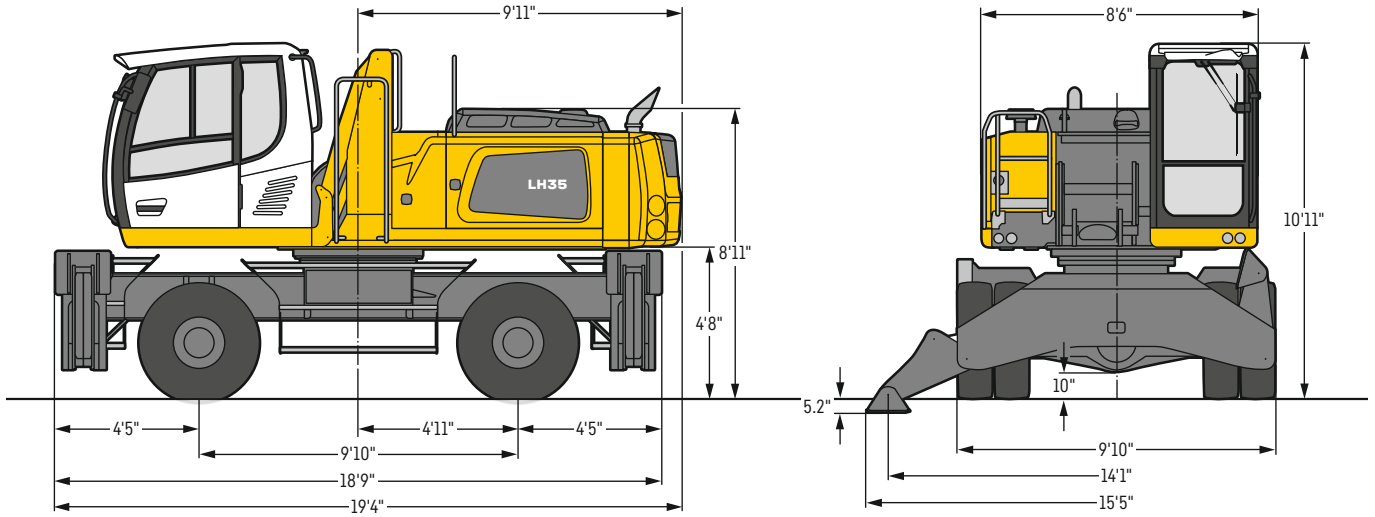

LH 35 M – Choice of cab elevation

Cab elevation LFC 120 (rigid elevation)

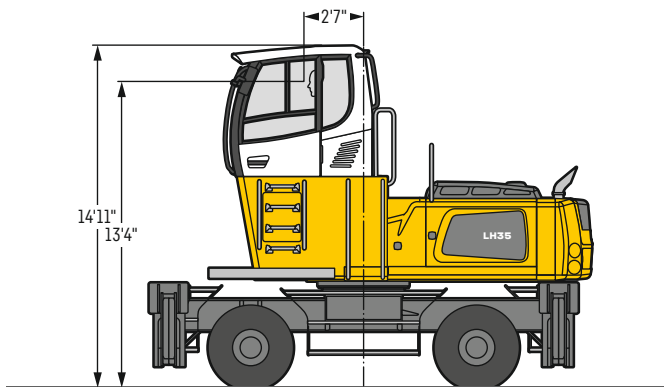

A rigid cab elevation has a fixed eye level height. For a lower transport height, the shell of the cab can be removed and replaced by a transport device. The dimension 14'11" is in this machine design for all rigid cab elevations 11'11".

Cab elevation LHC 255 (hydraulic elevation)

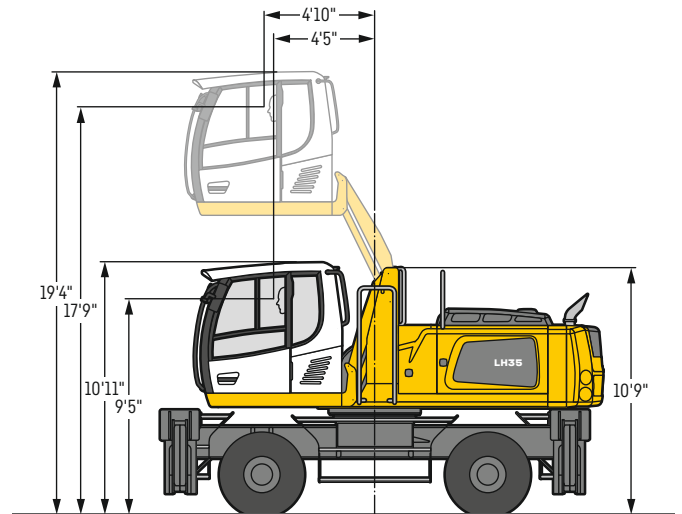

The hydraulically adjustable cab allows the driver, that he can choose his field of view freely and at any time within the stroke.

LH 30 C LC – Dimensions

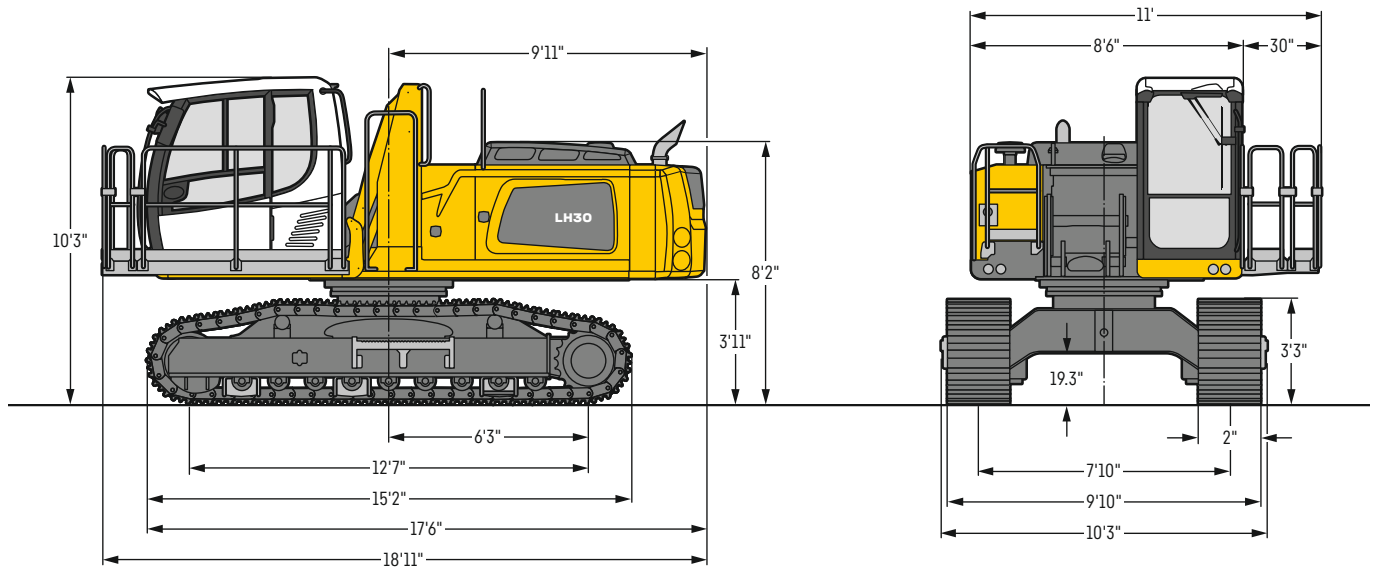

LH 30 C LC – Choice of cab elevation

Cab elevation LFC 120 (rigid elevation)

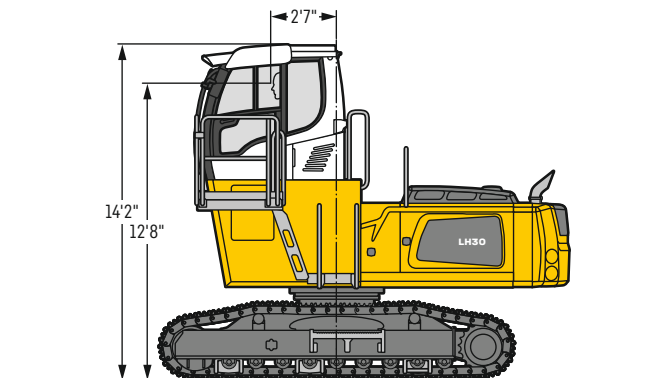

A rigid cab elevation has a fixed eye level height. For a lower transport height, the shell of the cab can be removed and replaced by a transport device. The dimension 14'2" is in this machine design for all rigid cab elevations 11'3".

Cab elevation LHC 255 (hydraulic elevation)

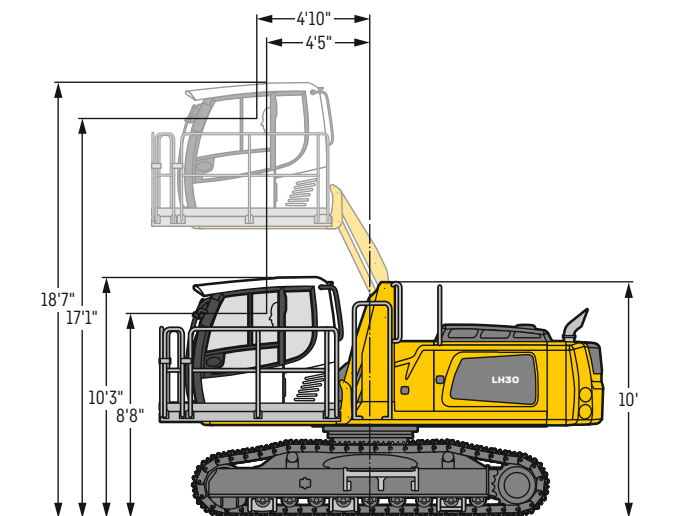

The hydraulically adjustable cab allows the driver, that he can choose his field of view freely and at any time within the stroke.

LH 30 C EW – Dimensions

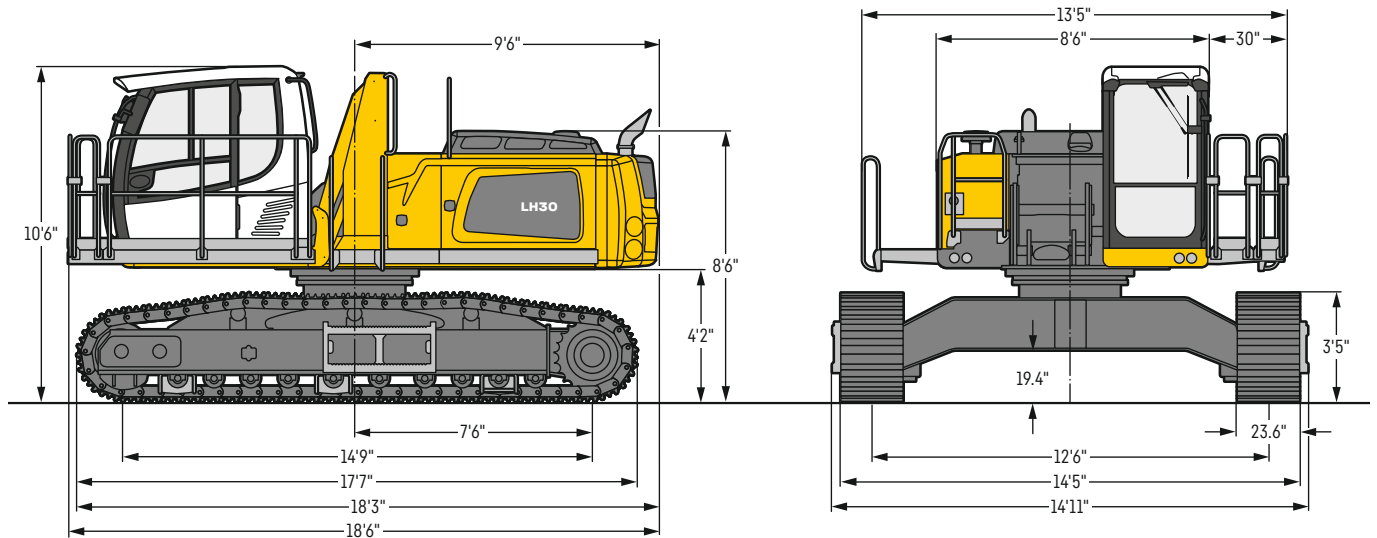

LH 30 C EW – Choice of cab elevation

Cab elevation LFC 120 (rigid elevation)

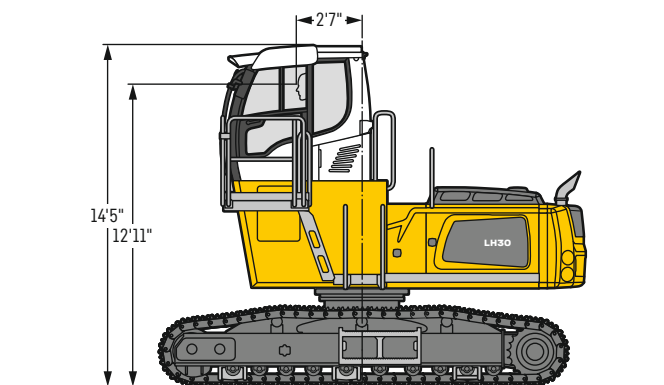

A rigid cab elevation has a fixed eye level height. For a lower transport height, the shell of the cab can be removed and replaced by a transport device. The dimension 14'5" is in this machine design for all rigid cab elevations 11'6".

Cab elevation LHC 255 (hydraulic elevation)

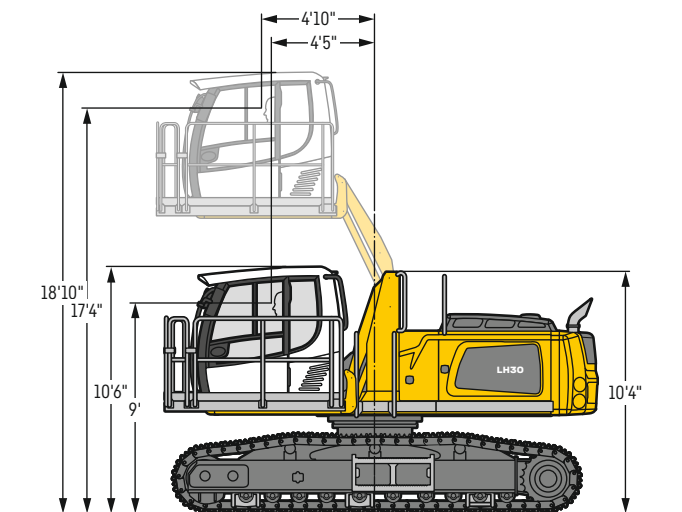

The hydraulically adjustable cab allows the driver, that he can choose his field of view freely and at any time within the stroke.

LH 30 M – Equipment AF11

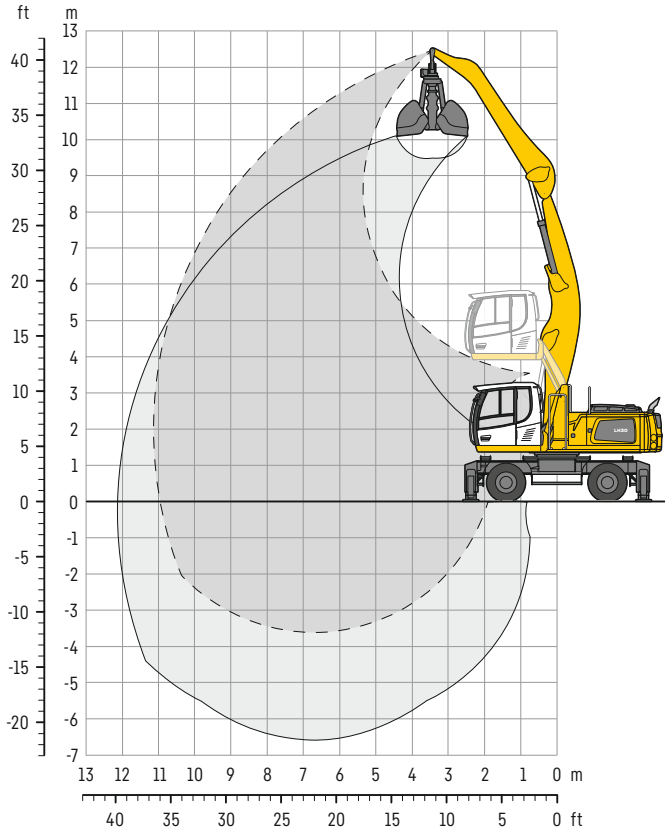

Dimensions

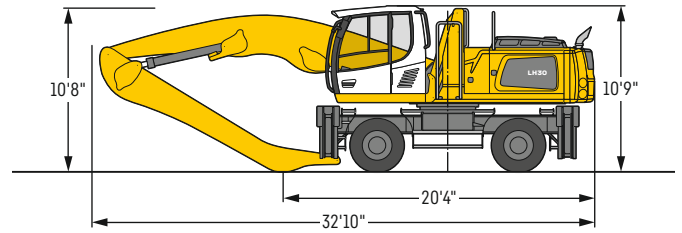

Operating weight

The operating weight includes the basic machine with 4 point outriggers, hydr. cab elevation, 8 solid tires plus intermediate rings, angled boom 21'4", flat angled stick 16'5" and grab for loose material GM 20C/1.96 yd³.

Weight 63,300 lb

ft	Undercarriage	10ft		15ft		20ft		25ft		30ft		35ft		40ft		45ft		ft in		
		Can be slewed through 360°	In longitudinal position of undercarriage	Can be slewed through 360°	In longitudinal position of undercarriage	Can be slewed through 360°	In longitudinal position of undercarriage	Can be slewed through 360°	In longitudinal position of undercarriage	Can be slewed through 360°	In longitudinal position of undercarriage	Can be slewed through 360°	In longitudinal position of undercarriage	Can be slewed through 360°	In longitudinal position of undercarriage	Can be slewed through 360°	In longitudinal position of undercarriage			
40	Stabilizers raised																	14,2*	14,2*	13'10"
	4 pt. outriggers down																	14,2*	14,2*	
35	Stabilizers raised					13,0	14,2*											10,4	11,0*	22' 8"
	4 pt. outriggers down					14,2*	14,2*											11,0*	11,0*	
30	Stabilizers raised					13,3	15,9*	9,1	12,0									7,4	9,8	27'11"
	4 pt. outriggers down					15,9*	15,9*	13,9*	13,9*									9,9*	9,9*	
25	Stabilizers raised					13,3	15,9*	9,2	12,0	6,6	8,8							6,0	8,0	31' 6"
	4 pt. outriggers down					15,9*	15,9*	14,2*	14,2*	12,1*	12,1*							9,4*	9,4*	
20	Stabilizers raised					12,9	16,6*	9,0	11,8	6,5	8,7							5,1	7,0	34'
	4 pt. outriggers down					16,6*	16,6*	14,6*	14,6*	12,9	13,0*							9,3*	9,3*	
15	Stabilizers raised			19,0	22,2*	12,2	16,1	8,6	11,4	6,3	8,5	4,8	6,5					4,6	6,3	35' 7"
	4 pt. outriggers down			22,2*	22,2*	18,0*	18,0*	15,2*	15,2*	12,7	13,2*	9,8	10,8*					9,4*	9,4*	
10	Stabilizers raised	31,4	38,9*	17,0	23,5	11,2	15,1	8,0	10,8	6,0	8,2	4,6	6,4					4,3	6,0	36' 5"
	4 pt. outriggers down	38,9*	38,9*	25,7*	25,7*	19,6*	19,6*	15,9*	15,9*	12,3	13,5*	9,7	11,4*					9,1	9,6*	
5	Stabilizers raised	13,0*	13,0*	15,0	21,2	10,2	14,1	7,5	10,2	5,7	7,8	4,5	6,2					4,2	5,8	36' 6"
	4 pt. outriggers down	13,0*	13,0*	28,2*	28,2*	20,7*	20,7*	15,7	16,4*	12,0	13,5*	9,5	11,1*					8,9	10,2*	
0	Stabilizers raised	10,7*	10,7*	13,7	19,7	9,4	13,2	7,0	9,7	5,4	7,6	4,3	6,1					4,2	5,9	35'11"
	4 pt. outriggers down	10,7*	10,7*	28,3*	28,3*	20,8*	20,8*	15,2	16,3*	11,7	13,1*	9,4	10,3*					9,0	9,6*	
-5	Stabilizers raised	12,6*	12,6*	13,0	19,0	8,9	12,7	6,7	9,4	5,3	7,4							4,4	6,1	34' 7"
	4 pt. outriggers down	12,6*	12,6*	25,5*	25,5*	19,5*	19,5*	14,8	15,3*	11,5	12,0*							8,9*	8,9*	
-10	Stabilizers raised			12,9	18,9	8,8	12,5	6,6	9,3									5,3	7,5	29' 7"
	4 pt. outriggers down			21,2*	21,2*	16,7*	16,7*	13,0*	13,0*									9,9*	9,9*	

Height Can be slewed through 360° In longitudinal position of undercarriage Max. reach * Limited by hydr. capacity

The lift capacities on the stick end without attachment are stated in lb x 1,000 and are valid on a firm, level supporting surface with blocked oscillating axle. These capacities can be slewed through 360° with the undercarriage in the transverse position. Capacities in the longitudinal position of the undercarriage (± 15°) are specified over the steering axle with the stabilizers raised and over the rigid axle with the stabilizers down. Indicated loads based on the ISO 10567 standard and do not exceed 75% of tipping or 87% of hydraulic capacity. The lift capacity of the unit is limited by its stability, the lifting capability of the hydraulic elements, or the maximum permissible lifting capacity of the load hook.

LH 30 M – Equipment GA12

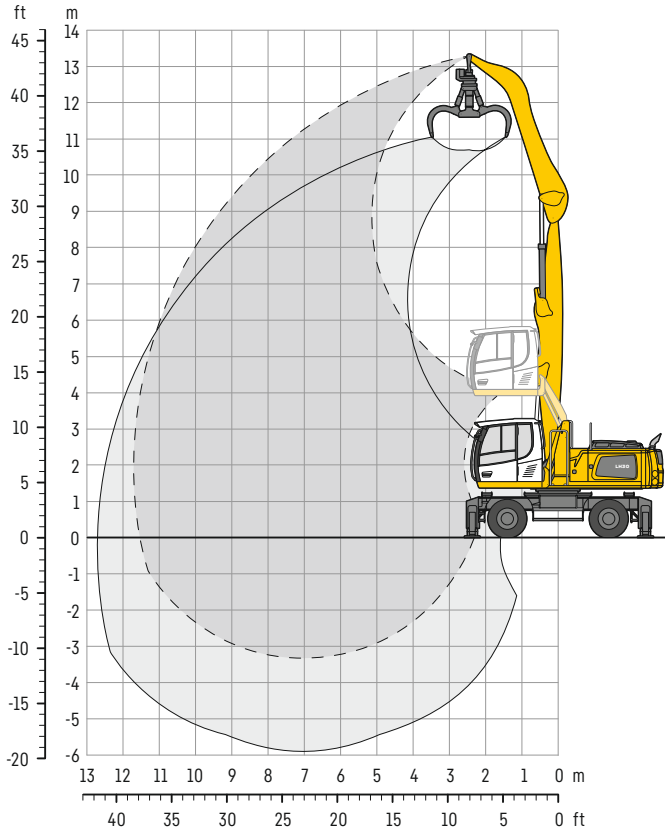

Dimensions

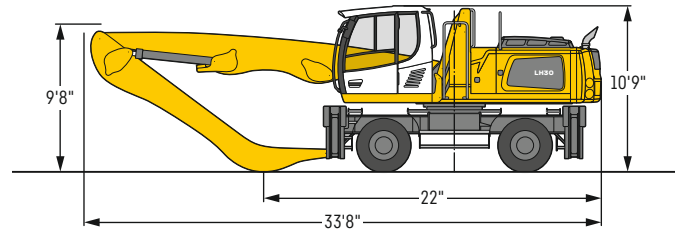

Operating weight

The operating weight includes the basic machine with 4 point outriggers, hydr. cab elevation, 8 solid tires plus intermediate rings, straight boom 22'4", angled stick 16'5" and multi-tine grab GM 65 / 0.78 yd³ semi-closed tines.

Weight 62,600 lb

ft	Undercarriage	10 ft		15 ft		20 ft		25 ft		30 ft		35 ft		40 ft		45 ft		ft in		
		Can be slewed through 360°	In longitudinal position of undercarriage	Can be slewed through 360°	In longitudinal position of undercarriage	Can be slewed through 360°	In longitudinal position of undercarriage	Can be slewed through 360°	In longitudinal position of undercarriage	Can be slewed through 360°	In longitudinal position of undercarriage	Can be slewed through 360°	In longitudinal position of undercarriage	Can be slewed through 360°	In longitudinal position of undercarriage					
40	Stabilizers raised			17,8*	17,8*													13,9*	13,9*	18' 2"
	4 pt. outriggers down			17,8*	17,8*													13,9*	13,9*	
35	Stabilizers raised					12,8	16,8	8,6	11,4									8,3	11,0	25' 6"
	4 pt. outriggers down					17,4*	17,4*	12,3*	12,3*									11,3*	11,3*	
30	Stabilizers raised					13,0	17,1	9,0	11,8	6,3	8,5							6,2	8,3	30' 4"
	4 pt. outriggers down					17,4*	17,4*	15,2*	15,2*	10,8*	10,8*							10,1*	10,1*	
25	Stabilizers raised					12,9	16,9	8,9	11,7	6,5	8,6							5,1	7,0	33' 7"
	4 pt. outriggers down					17,5*	17,5*	15,2*	15,2*	12,8	13,3*							9,6*	9,6*	
20	Stabilizers raised			19,6	22,0*	12,4	16,4	8,7	11,5	6,3	8,5	4,7	6,5					4,5	6,2	36'
	4 pt. outriggers down			22,0*	22,0*	18,2*	18,2*	15,5*	15,5*	12,7	13,4*	9,8	11,5*					9,3*	9,3*	
15	Stabilizers raised	21,7*	21,7*	18,1	24,7	11,6	15,6	8,2	11,0	6,1	8,3	4,7	6,4					4,1	5,7	37' 6"
	4 pt. outriggers down	21,7*	21,7*	24,7*	24,7*	19,4*	19,4*	16,0*	16,0*	12,4	13,5*	9,7	11,4*					8,7	9,3*	
10	Stabilizers raised	29,2	42,6*	16,1	22,4	10,7	14,6	7,7	10,5	5,8	7,9	4,5	6,2					3,9	5,4	38' 2"
	4 pt. outriggers down	42,6*	42,6*	27,5*	27,5*	20,5*	20,5*	15,9	16,4*	12,1	13,6*	9,5	11,2*					8,3	9,4*	
5	Stabilizers raised	5,5*	5,5*	14,2	20,3	9,7	13,5	7,2	9,9	5,5	7,6	4,3	6,1					3,8	5,3	38' 5"
	4 pt. outriggers down	5,5*	5,5*	28,7*	28,7*	21,0*	21,0*	15,3	16,5*	11,7	13,3*	9,4	10,7*					8,2	8,5*	
0	Stabilizers raised	6,5*	6,5*	13,1	19,1	9,0	12,8	6,7	9,4	5,3	7,4	4,2	5,9					3,8	5,4	37'10"
	4 pt. outriggers down	6,5*	6,5*	21,2*	21,2*	20,2*	20,2*	14,8	15,7*	11,4	12,5*	9,2	9,6*					7,4*	7,4*	
-5	Stabilizers raised			12,6	18,6	8,6	12,4	6,5	9,2	5,1	7,2	4,2	5,9					4,1	5,8	35' 8"
	4 pt. outriggers down			19,8*	19,8*	17,8*	17,8*	14,0*	14,0*	10,9*	10,9*	7,6*	7,6*					7,0*	7,0*	
-10	Stabilizers raised					8,6	12,3	6,4	9,1									5,5	7,7	28' 5"
	4 pt. outriggers down					13,9*	13,9*	11,0*	11,0*									9,1*	9,1*	

Height Can be slewed through 360° In longitudinal position of undercarriage Max. reach * Limited by hydr. capacity

The lift capacities on the stick end without attachment are stated in lb x 1,000 and are valid on a firm, level supporting surface with blocked oscillating axle. These capacities can be slewed through 360° with the undercarriage in the transverse position. Capacities in the longitudinal position of the undercarriage (± 15°) are specified over the steering axle with the stabilizers raised and over the rigid axle with the stabilizers down. Indicated loads based on the ISO 10567 standard and do not exceed 75% of tipping or 87% of hydraulic capacity. The lift capacity of the unit is limited by its stability, the lifting capability of the hydraulic elements, or the maximum permissible lifting capacity of the load hook.

LH 30 M – Equipment GA13

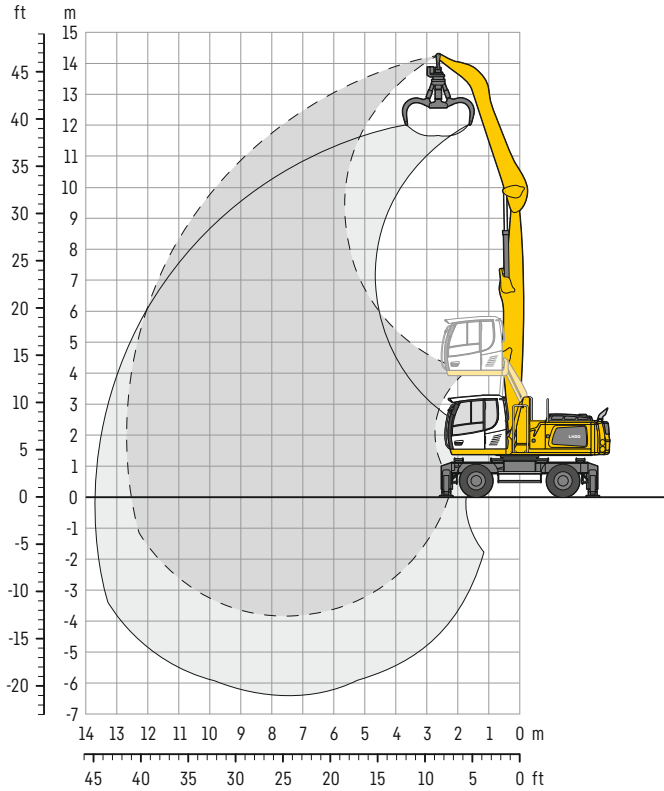

Dimensions

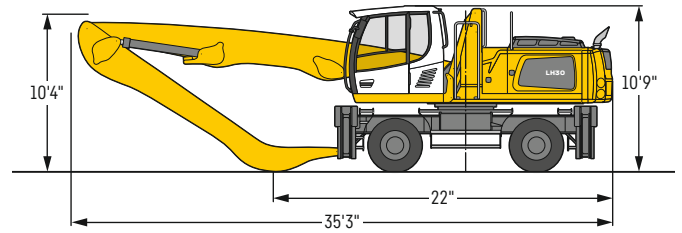

Operating weight

The operating weight includes the basic machine with 4 point outriggers, hydr. cab elevation, 8 solid tires plus intermediate rings, straight boom 23'11", angled stick 18'1" and multi-tine grab GM 65 / 0.78 yd³ semi-closed tines.

Weight 63,300 lb

ft	Undercarriage	10ft		15ft		20ft		25ft		30ft		35ft		40ft		45ft		ft in		
		☐	☒	☐	☒	☐	☒	☐	☒	☐	☒	☐	☒	☐	☒	☐	☒	☐	☒	
45	Stabilizers raised																	15,0*	15,0*	14' 11"
	4 pt. outriggers down					12,8	15,5*											15,0*	15,0*	
40	Stabilizers raised					13,3	16,7*	9,1	11,9	6,3	8,5							8,9	11,1*	24' 5"
	4 pt. outriggers down					15,5*	15,5*	13,4	16,5*	9,2	12,0	6,6	8,8					11,1*	11,1*	
35	Stabilizers raised					16,7*	16,7*	14,6*	14,6*	10,0*	10,0*							6,2	8,4	30' 2"
	4 pt. outriggers down					13,1	16,8*	9,0	11,9	6,5	8,7	4,8	6,6					9,6*	9,6*	
30	Stabilizers raised					16,5*	16,5*	14,3*	14,3*	12,7*	12,7*							4,9	6,7	34' 4"
	4 pt. outriggers down					13,1	16,8*	14,5*	14,5*	12,7*	12,7*	9,9	11,2*					8,9*	8,9*	
25	Stabilizers raised					12,5	16,6	8,7	11,5	6,3	8,5	4,7	6,5					4,1	5,7	37' 4"
	4 pt. outriggers down					17,6*	17,6*	14,9*	14,9*	12,7	12,8*	9,8	11,2*					8,5*	8,5*	
20	Stabilizers raised	18,0*	18,0*	18,2	24,1*	11,6	15,6	8,1	11,0	6,0	8,2	4,6	6,3	3,5	5,0			3,3	4,8	40' 10"
	4 pt. outriggers down	18,0*	18,0*	24,1*	24,1*	18,8*	18,8*	15,4*	15,4*	12,3	13,0*	9,6	11,1*	7,7	9,3*			7,5	8,3*	
15	Stabilizers raised	28,7	32,0*	15,8	22,2	10,5	14,3	7,5	10,3	5,6	7,8	4,3	6,1	3,4	4,9			3,1	4,5	41' 6"
	4 pt. outriggers down	32,0*	32,0*	26,8*	26,8*	19,9*	19,9*	15,8	15,9*	11,9	13,2*	9,4	11,0*	7,6	9,0*			7,2	8,1*	
10	Stabilizers raised	3,9*	3,9*	13,6	19,7	9,3	13,1	6,9	9,6	5,2	7,4	4,1	5,8	3,3	4,7			3,1	4,5	41' 7"
	4 pt. outriggers down	3,9*	3,9*	27,9*	27,9*	20,4*	20,4*	15,0	16,0*	11,5	13,0*	9,1	10,7*	7,5	8,4*			7,1	7,4*	
5	Stabilizers raised	4,8*	4,8*	12,3	16,0*	8,5	12,2	6,3	9,1	4,9	7,0	3,9	5,7	3,2	4,7			3,1	4,5	41' 1"
	4 pt. outriggers down	4,8*	4,8*	16,0*	16,0*	19,8*	19,8*	14,4	15,5*	11,1	12,4*	8,9	10,0*	7,3*	7,3*			6,5*	6,5*	
-5	Stabilizers raised			11,7	15,3*	8,0	11,7	6,0	8,7	4,7	6,8	3,8	5,5					3,3	4,7	39' 5"
	4 pt. outriggers down			15,3*	15,3*	17,7*	17,7*	14,0*	14,0*	10,9	11,2*	8,6*	8,6*					5,9*	5,9*	
-10	Stabilizers raised			7,9	11,6	5,9	8,6	4,6	6,7									3,9	5,7	34' 1"
	4 pt. outriggers down			14,3*	14,3*	11,6*	11,6*	9,0*	9,0*									6,9*	6,9*	

☐ Height ☐ Can be slewed through 360° ☒ In longitudinal position of undercarriage ☐ Max. reach * Limited by hydr. capacity

The lift capacities on the stick end without attachment are stated in lb x 1,000 and are valid on a firm, level supporting surface with blocked oscillating axle. These capacities can be slewed through 360° with the undercarriage in the transverse position. Capacities in the longitudinal position of the undercarriage (± 15°) are specified over the steering axle with the stabilizers raised and over the rigid axle with the stabilizers down. Indicated loads based on the ISO 10567 standard and do not exceed 75% of tipping or 87% of hydraulic capacity. The lift capacity of the unit is limited by its stability, the lifting capability of the hydraulic elements, or the maximum permissible lifting capacity of the load hook.

LH 30 M – Equipment GA13

with heavy counterweight

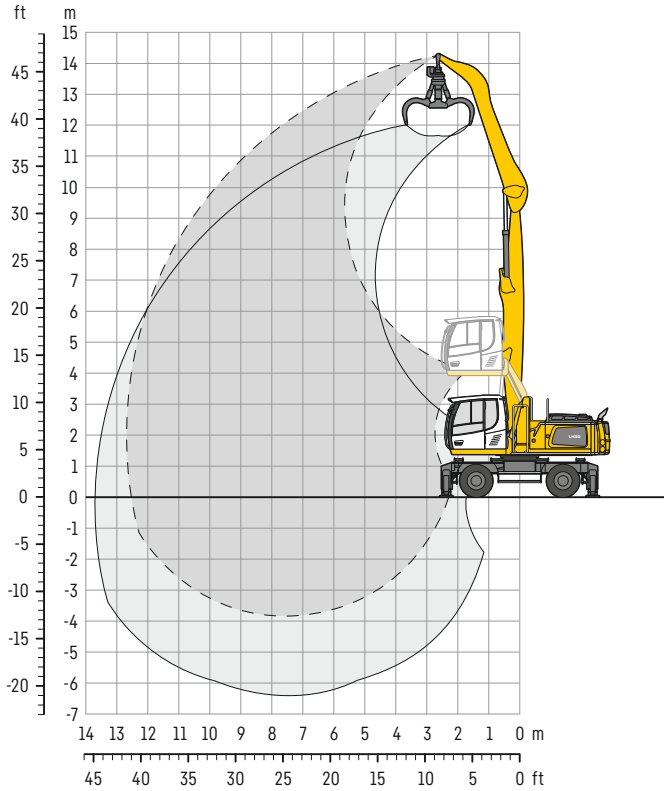

Dimensions

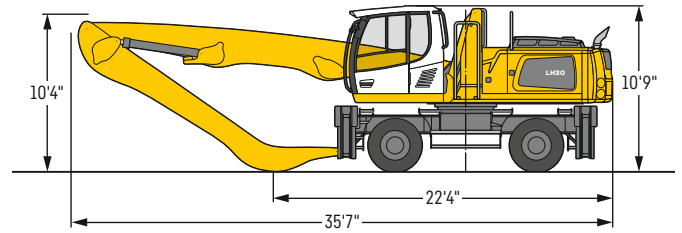

Operating weight

The operating weight includes the basic machine with 4 point outriggers, hydr. cab elevation, 8 solid tires plus intermediate rings, straight boom 23'11", angled stick 18'1" and multi-tine grab GM 65 / 0.78 yd³ semi-closed tines.

Weight 66,700 lb

ft	Undercarriage	10ft		15ft		20ft		25ft		30ft		35ft		40ft		45ft		ft in		
		Can be slewed through 360°	In longitudinal position of undercarriage	Can be slewed through 360°	In longitudinal position of undercarriage	Can be slewed through 360°	In longitudinal position of undercarriage	Can be slewed through 360°	In longitudinal position of undercarriage	Can be slewed through 360°	In longitudinal position of undercarriage	Can be slewed through 360°	In longitudinal position of undercarriage	Can be slewed through 360°	In longitudinal position of undercarriage	Can be slewed through 360°	In longitudinal position of undercarriage	Can be slewed through 360°	In longitudinal position of undercarriage	
45	Stabilizers raised																	15,0*	15,0*	14'11"
	4 pt. outriggers down					14,8	15,5*											15,0*	15,0*	
40	Stabilizers raised					15,3	16,7*	10,6	13,7	7,6	9,9							10,5	11,1*	24' 5"
	4 pt. outriggers down					15,5*	16,7*	14,6*	14,6*	10,0*	10,0*							11,1*	11,1*	
35	Stabilizers raised					16,7*	16,7*	10,7	13,8	7,8	10,2							7,5	9,6*	30' 2"
	4 pt. outriggers down					16,7*	16,7*	14,6*	14,6*	10,0*	10,0*							9,6*	9,6*	
30	Stabilizers raised					15,4	16,5*	10,6	13,7	7,8	10,2							6,0	7,9	34' 4"
	4 pt. outriggers down					16,5*	16,5*	14,3*	14,3*	12,7*	12,7*							8,9*	8,9*	
25	Stabilizers raised					15,1	16,8*	10,6	13,7	7,8	10,2	5,9	7,8					5,1	6,9	37' 4"
	4 pt. outriggers down					16,8*	16,8*	14,5*	14,5*	12,7*	12,7*	11,2*	11,2*					8,5*	8,5*	
20	Stabilizers raised					14,6	17,6*	10,2	13,3	7,6	9,9	5,8	7,7					4,6	6,2	39' 5"
	4 pt. outriggers down					17,6*	17,6*	14,9*	14,9*	12,8*	12,8*	11,2*	11,2*					8,3*	8,3*	
15	Stabilizers raised	18,0*	18,0*	21,1	24,1*	13,6	17,9	9,7	12,7	7,3	9,6	5,6	7,5	4,4	6,0			4,2	5,8	40'10"
	4 pt. outriggers down	18,0*	18,0*	24,1*	24,1*	18,8*	18,8*	15,4*	15,4*	13,0*	13,0*	11,1	11,1*	8,9	9,3*			8,3*	8,3*	
10	Stabilizers raised	32,0*	32,0*	18,7	25,7	12,5	16,7	9,1	12,1	6,9	9,2	5,4	7,3	4,3	5,9			4,0	5,5	41' 6"
	4 pt. outriggers down	32,0*	32,0*	26,8*	26,8*	19,9*	19,9*	15,9*	15,9*	13,2*	13,2*	10,8	11,0*	8,8	9,0*			8,1*	8,1*	
5	Stabilizers raised	3,9*	3,9*	16,5	23,2	11,4	15,5	8,4	11,4	6,5	8,8	5,2	7,0	4,2	5,8			3,9	5,4	41' 7"
	4 pt. outriggers down	3,9*	3,9*	27,9*	27,9*	20,4*	20,4*	16,0*	16,0*	13,0*	13,0*	10,6	10,7*	8,4*	8,4*			7,4*	7,4*	
0	Stabilizers raised	4,8*	4,8*	15,2	16,0*	10,5	14,6	7,9	10,8	6,2	8,5	5,0	6,9	4,1	5,7			4,0	5,5	41' 1"
	4 pt. outriggers down	4,8*	4,8*	16,0*	16,0*	19,8*	19,8*	15,5*	15,5*	12,4*	12,4*	10,0*	10,0*	7,3*	7,3*			6,5*	6,5*	
-5	Stabilizers raised			14,6	15,3*	10,1	14,1	7,6	10,5	6,0	8,3	4,9	6,7					4,2	5,8	39' 5"
	4 pt. outriggers down			15,3*	15,3*	17,7*	17,7*	14,0*	14,0*	11,2*	11,2*	8,6*	8,6*					5,9*	5,9*	
-10	Stabilizers raised					9,9	13,9	7,4	10,3	5,9	8,2							5,0	6,9*	34' 1"
	4 pt. outriggers down					14,3*	14,3*	11,6*	11,6*	9,0*	9,0*							6,9*	6,9*	

Height Can be slewed through 360° In longitudinal position of undercarriage Max. reach * Limited by hydr. capacity

The lift capacities on the stick end without attachment are stated in lb x 1,000 and are valid on a firm, level supporting surface with blocked oscillating axle. These capacities can be slewed through 360° with the undercarriage in the transverse position. Capacities in the longitudinal position of the undercarriage (± 15°) are specified over the steering axle with the stabilizers raised and over the rigid axle with the stabilizers down. Indicated loads based on the ISO 10567 standard and do not exceed 75% of tipping or 87% of hydraulic capacity. The lift capacity of the unit is limited by its stability, the lifting capability of the hydraulic elements, or the maximum permissible lifting capacity of the load hook.

LH 30 M – Equipment GA14

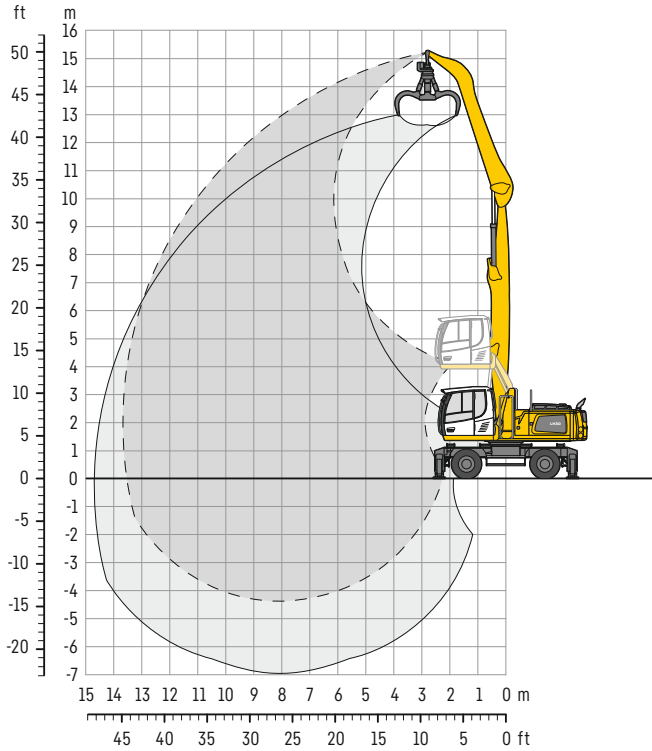

Dimensions

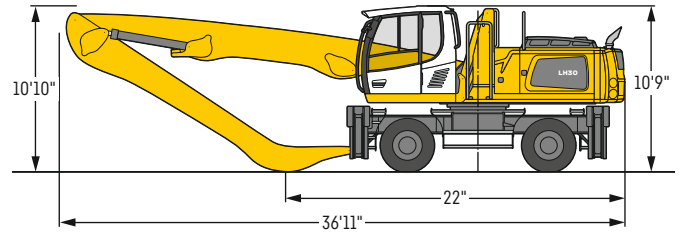

Operating weight

The operating weight includes the basic machine with 4 point outriggers, hydr. cab elevation, 8 solid tires plus intermediate rings, straight boom 25'7", angled stick 19'8" and multi-tine grab GM 65 / 0.78 yd³ semi-closed tines.

Weight 63,700 lb

ft	10ft		15ft		20ft		25ft		30ft		35ft		40ft		45ft		ft in		
	☐	☒	☐	☒	☐	☒	☐	☒	☐	☒	☐	☒	☐	☒	☐	☒	☐	☒	
45	Stabilizers raised				12.6	13.6*											10.1	11.2*	22' 7"
	4 pt. outriggers down				13.6*	13.6*											11.2*	11.2*	
40	Stabilizers raised				13.4	15.8*	9.1	12.0									6.4	8.7	29' 7"
	4 pt. outriggers down				15.8*	15.8*	13.5*	13.5*									9.3*	9.3*	
35	Stabilizers raised				13.7	15.9*	9.4	12.3	6.7	8.9							4.8	6.6	34' 7"
	4 pt. outriggers down				15.9*	15.9*	13.8*	13.8*	12.2*	12.2*							8.4*	8.4*	
30	Stabilizers raised				9.4	12.3	6.7	8.9	4.9	6.7							3.9	5.5	38' 2"
	4 pt. outriggers down				13.7*	13.7*	12.1*	12.1*	10.0	10.7*							7.9*	7.9*	
25	Stabilizers raised				13.4	16.2*	9.2	12.1	6.6	8.8	4.9	6.6	3.6	5.0			3.3	4.8	40'11"
	4 pt. outriggers down				16.2*	16.2*	13.9*	13.9*	12.2*	12.2*	10.0	10.7*	7.8	9.2*			7.5	7.6*	
20	Stabilizers raised				12.6	16.7	8.7	11.6	6.3	8.5	4.7	6.5	3.5	5.0			3.0	4.3	42'10"
	4 pt. outriggers down				17.1*	17.1*	14.4*	14.4*	12.4*	12.4*	9.8	10.8*	7.8	9.3*			6.9	7.5*	
15	Stabilizers raised		15.0*	15.0*	18.2	21.8*	11.6	15.6	8.1	10.9	5.9	8.1	4.5	6.2	3.4	4.9	2.7	4.0	44' 1"
	4 pt. outriggers down		15.0*	15.0*	21.8*	21.8*	18.3*	18.3*	15.0*	15.0*	12.3	12.6*	9.6	10.8*	7.7	9.2*	6.4	7.5*	
10	Stabilizers raised		21.3*	21.3*	15.6	21.9	10.3	14.2	7.3	10.1	5.5	7.6	4.2	5.9	3.2	4.7	2.6	3.8	44' 8"
	4 pt. outriggers down		21.3*	21.3*	26.2*	26.2*	19.4*	19.4*	15.5*	15.5*	11.8	12.8*	9.3	10.8*	7.5	9.0*	6.2	7.1*	
5	Stabilizers raised		2.7*	2.7*	13.1	19.1	9.0	12.8	6.6	9.3	5.0	7.2	3.9	5.6	3.1	4.6	2.5	3.8	44'10"
	4 pt. outriggers down		2.7*	2.7*	22.6*	22.6*	19.9*	19.9*	14.8	15.6*	11.3	12.7*	8.9	10.5*	7.3	8.7*	6.1	6.5*	
0	Stabilizers raised		3.6*	3.6*	11.5	12.4*	8.0	11.8	6.0	8.7	4.6	6.7	3.7	5.4	2.9	4.4	2.5	3.8	44' 5"
	4 pt. outriggers down		3.6*	3.6*	12.4*	12.4*	19.3*	19.3*	14.1	15.1*	10.8	12.2*	8.7	10.0*	7.2	8.0*	5.7*	5.7*	
-5	Stabilizers raised		5.8*	5.8*	10.8	12.1*	7.5	11.1	5.6	8.3	4.4	6.5	3.5	5.2	2.9	4.3	2.6	3.9	43' 1"
	4 pt. outriggers down		5.8*	5.8*	12.1*	12.1*	17.4*	17.4*	13.6	13.9*	10.5	11.2*	8.5	9.0*	6.8*	6.8*	4.9*	4.9*	
-10	Stabilizers raised		10.7	13.7*	7.2	10.9	5.4	8.1	4.2	6.3	3.4	5.1	2.9	4.3	2.6	3.9	3.0	4.5	38' 8"
	4 pt. outriggers down		13.7*	13.7*	14.5*	14.5*	11.8*	11.8*	9.5*	9.5*	7.3*	7.3*	5.6*	5.6*			5.6*	5.6*	

☐ Can be slewed through 360° ☒ In longitudinal position of undercarriage ☒ Max. reach * Limited by hydr. capacity

The lift capacities on the stick end without attachment are stated in lb x 1,000 and are valid on a firm, level supporting surface with blocked oscillating axle. These capacities can be slewed through 360° with the undercarriage in the transverse position. Capacities in the longitudinal position of the undercarriage (± 15°) are specified over the steering axle with the stabilizers raised and over the rigid axle with the stabilizers down. Indicated loads based on the ISO 10567 standard and do not exceed 75% of tipping or 87% of hydraulic capacity. The lift capacity of the unit is limited by its stability, the lifting capability of the hydraulic elements, or the maximum permissible lifting capacity of the load hook.

LH 30 M – Equipment GA14

with heavy counterweight

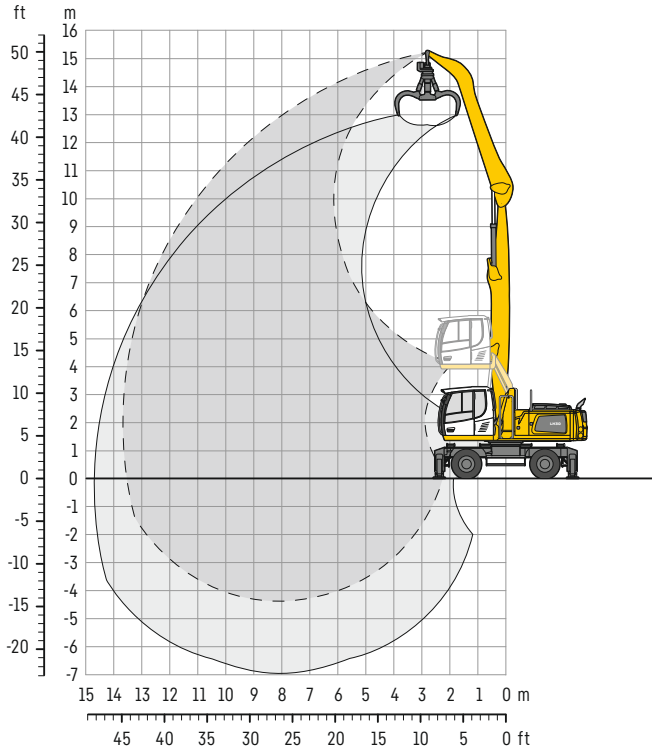

Dimensions

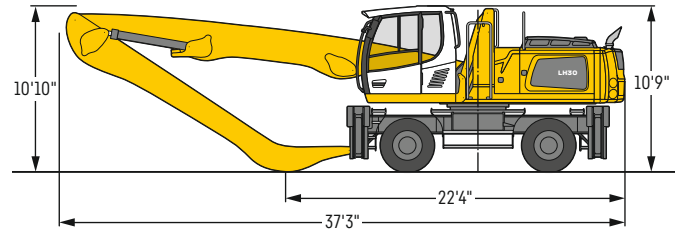

Operating weight

The operating weight includes the basic machine with 4 point outriggers, hydr. cab elevation, 8 solid tires plus intermediate rings, straight boom 25'7", angled stick 19'8" and multi-tine grab GM 65 / 0.78 yd³ semi-closed tines.

Weight 67,200 lb

ft	Undercarriage	10ft		15ft		20ft		25ft		30ft		35ft		40ft		45ft		ft in		
		☐	☒	☐	☒	☐	☒	☐	☒	☐	☒	☐	☒	☐	☒	☐	☒			
45	Stabilizers raised					13.6*	13.6*											11.2*	11.2*	22' 7"
	4 pt. outriggers down					13.6*	13.6*											11.2*	11.2*	
40	Stabilizers raised					15.5	15.8*	10.7	13.5*									7.7	9.3*	29' 7"
	4 pt. outriggers down					15.8*	15.8*	13.5*	13.5*									9.3*	9.3*	
35	Stabilizers raised					15.8	15.9*	11.0	13.8*	7.9	10.3							5.9	7.9	34' 7"
	4 pt. outriggers down					15.9*	15.9*	13.8*	13.8*	12.2*	12.2*							8.4*	8.4*	
30	Stabilizers raised					11.0	13.7*	11.0	13.7*	8.0	10.4	6.0	7.9					4.9	6.6	38' 2"
	4 pt. outriggers down					13.7*	13.7*	12.1*	12.1*	12.1*	12.1*	10.7*	10.7*					7.9*	7.9*	
25	Stabilizers raised					15.4	16.2*	10.7	13.8	7.9	10.2	5.9	7.8	4.5	6.1			4.2	5.8	40'11"
	4 pt. outriggers down					16.2*	16.2*	13.9*	13.9*	12.2*	12.2*	10.7*	10.7*	9.1	9.2*			7.6*	7.6*	
20	Stabilizers raised					14.7	17.1*	10.3	13.4	7.6	10.0	5.8	7.7	4.4	6.0			3.8	5.3	42'10"
	4 pt. outriggers down					17.1*	17.1*	14.4*	14.4*	12.4*	12.4*	10.8*	10.8*	9.0	9.3*			7.5*	7.5*	
15	Stabilizers raised	15.0*	15.0*	21.1	21.8*	13.6	17.9	9.6	12.7	7.2	9.5	5.5	7.4	4.3	5.9			3.5	4.9	44' 1"
	4 pt. outriggers down	15.0*	15.0*	21.8*	21.8*	18.3*	18.3*	15.0*	15.0*	12.6*	12.6*	10.8*	10.8*	8.9	9.2*			7.5*	7.5*	
10	Stabilizers raised	21.3*	21.3*	18.5	25.4	12.3	16.5	8.9	11.9	6.7	9.1	5.3	7.1	4.2	5.8			3.4	4.7	44' 8"
	4 pt. outriggers down	21.3*	21.3*	26.2*	26.2*	19.4*	19.4*	15.5*	15.5*	12.8*	12.8*	10.7	10.8*	8.7	9.0*			7.1*	7.1*	
5	Stabilizers raised	2.7*	2.7*	16.0	22.6*	11.0	15.2	8.2	11.1	6.3	8.6	5.0	6.8	4.0	5.6			3.3	4.7	44'10"
	4 pt. outriggers down	2.7*	2.7*	22.6*	22.6*	19.9*	19.9*	15.6*	15.6*	12.7*	12.7*	10.4	10.5*	8.5	8.7*			6.5*	6.5*	
0	Stabilizers raised	3.6*	3.6*	12.4*	12.4*	10.0	14.1	7.5	10.5	5.9	8.2	4.7	6.6	3.9	5.4			3.3	4.7	44' 5"
	4 pt. outriggers down	3.6*	3.6*	12.4*	12.4*	19.3*	19.3*	15.1*	15.1*	12.2*	12.2*	10.0*	10.0*	8.0*	8.0*			5.7*	5.7*	
-5	Stabilizers raised	5.8*	5.8*	12.1*	12.1*	9.5	13.5	7.1	10.1	5.6	7.9	4.6	6.4	3.8	5.4			3.4	4.9	43' 1"
	4 pt. outriggers down	5.8*	5.8*	12.1*	12.1*	17.4*	17.4*	13.9*	13.9*	11.2*	11.2*	9.0*	9.0*	6.8*	6.8*			4.9*	4.9*	
-10	Stabilizers raised	13.6	13.7*	9.3	13.3	6.9	9.8	5.5	7.7	4.5	6.3	3.9	5.6	3.9	5.6			3.9	5.6	38' 8"
	4 pt. outriggers down	13.7*	13.7*	14.5*	14.5*	11.8*	11.8*	9.5*	9.5*	7.3*	7.3*	5.6*	5.6*	5.6*	5.6*			5.6*	5.6*	

☐ Height ☐ Can be slewed through 360° ☒ In longitudinal position of undercarriage ☐ Max. reach * Limited by hydr. capacity

The lift capacities on the stick end without attachment are stated in lb x 1,000 and are valid on a firm, level supporting surface with blocked oscillating axle. These capacities can be slewed through 360° with the undercarriage in the transverse position. Capacities in the longitudinal position of the undercarriage (± 15°) are specified over the steering axle with the stabilizers raised and over the rigid axle with the stabilizers down. Indicated loads based on the ISO 10567 standard and do not exceed 75% of tipping or 87% of hydraulic capacity. The lift capacity of the unit is limited by its stability, the lifting capability of the hydraulic elements, or the maximum permissible lifting capacity of the load hook.

LH 30 M – Equipment GS10

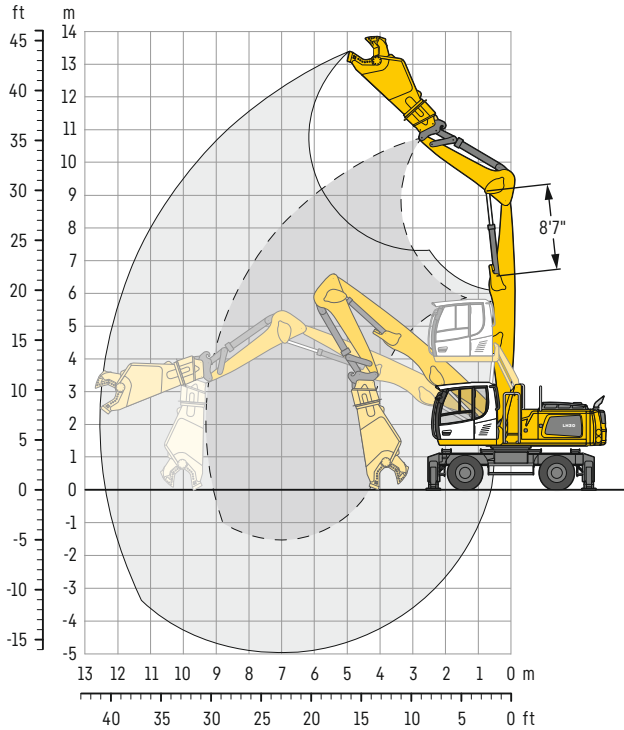

Dimensions

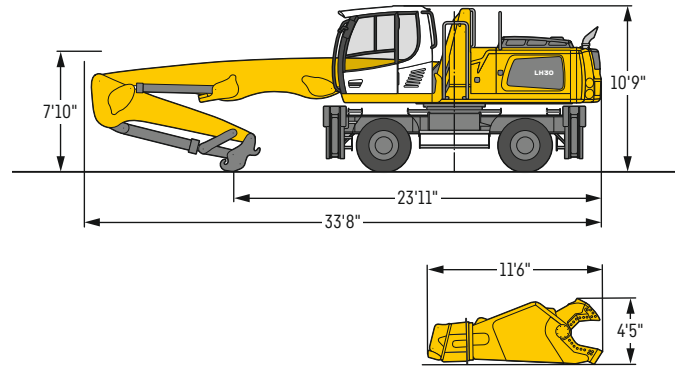

Operating weight

The operating weight includes the basic machine with 4 point outriggers, hydr. cab elevation, 8 solid tires plus intermediate rings, straight boom 22'4", stick HD with tipping kinematics special 10'6", quick coupler SWA 48 and scrap shear Genesis GXT 335R.

Weight 72,500 lb

A heavy counterweight (13,400 lb) is required for this attachment configuration. The stick cylinder must be limited to the measure of 8'7".

ft	Undercarriage	10ft		15ft		20ft		25ft		30ft		35ft		40ft		45ft		ft in	
		Stabilizers raised	4 pt. outriggers down	Stabilizers raised	4 pt. outriggers down	Stabilizers raised	4 pt. outriggers down	Stabilizers raised	4 pt. outriggers down	Stabilizers raised	4 pt. outriggers down	Stabilizers raised	4 pt. outriggers down	Stabilizers raised	4 pt. outriggers down	Stabilizers raised	4 pt. outriggers down		
45	Stabilizers raised																		
45	4 pt. outriggers down																		
40	Stabilizers raised					11,0*	11,0*											7,4	9,4*
40	4 pt. outriggers down					11,0*	11,0*											9,4*	9,4*
35	Stabilizers raised							6,7	8,2*									3,4	6,0
35	4 pt. outriggers down							8,2*	8,2*									6,7*	6,7*
30	Stabilizers raised							7,0	8,0*	3,4	5,9							1,5	3,6
30	4 pt. outriggers down							8,0*	8,0*	6,3*	6,3*							5,3*	5,3*
25	Stabilizers raised							6,8	8,0*	3,4	5,9	1,1	3,0					0,4	2,3
25	4 pt. outriggers down							8,0*	8,0*	6,3*	6,3*	4,9*	4,9*					4,4*	4,4*
20	Stabilizers raised							6,3	8,2*	3,1	5,5	0,9	2,9					-	1,4
20	4 pt. outriggers down							8,2*	8,2*	6,4*	6,4*	4,8*	4,8*					3,7*	3,7*
15	Stabilizers raised					9,2*	9,2*	5,5	8,6*	2,6	5,0	0,6	2,6	-	0,8			-	0,8
15	4 pt. outriggers down					9,2*	9,2*	8,6*	8,6*	6,5*	6,5*	4,8*	4,8*	3,2*	3,2*			3,1*	3,1*
10	Stabilizers raised			6,7*	6,7*	8,6	12,4*	4,5	7,6	1,9	4,3	0,2	2,2	-	0,6			-	0,4
10	4 pt. outriggers down			6,7*	6,7*	12,4*	12,4*	9,0*	9,0*	6,6*	6,6*	4,7*	4,7*	3,0*	3,0*			2,6*	2,6*
5	Stabilizers raised			12,6	19,5*	6,6	10,9	3,3	6,4	1,2	3,6	-	1,7	-	0,4			-	0,1
5	4 pt. outriggers down			19,5*	19,5*	13,0*	13,0*	9,2*	9,2*	6,5*	6,5*	4,4*	4,4*	2,5*	2,5*			2,0*	2,0*
0	Stabilizers raised			9,2	15,8	4,8	9,0	2,3	5,3	0,6	2,9	-	1,3	-	0,2			-	0,1
0	4 pt. outriggers down			19,5*	19,5*	12,9*	12,9*	8,9*	8,9*	6,1*	6,1*	3,9*	3,9*	1,7*	1,7*			1,4*	1,4*
-5	Stabilizers raised	0,9*	0,9*	7,1	13,5*	3,6	7,6	1,5	4,4	0,1	2,4	-	1,0					-	0,1
-5	4 pt. outriggers down	0,9*	0,9*	13,5*	13,5*	11,6*	11,6*	7,8*	7,8*	5,1*	5,1*	2,8*	2,8*					0,7*	0,7*
-10	Stabilizers raised	3,6*	3,6*	6,2	12,6	2,9	6,9	1,0	3,9	-	2,1	-	0,9					-	-
-10	4 pt. outriggers down	3,6*	3,6*	13,2*	13,2*	9,0*	9,0*	5,9*	5,9*	3,4*	3,4*	1,1*	1,1*					-	-
-15	Stabilizers raised					2,7	5,2*	0,9	2,9*									-	0,8*
-15	4 pt. outriggers down					5,2*	5,2*	2,9*	2,9*									0,8*	0,8*

Height Can be slewed through 360° In longitudinal position of undercarriage Max. reach * Limited by hydr. capacity

The lift capacities on the stick end without attachment are stated in lb x 1,000 and are valid on a firm, level supporting surface with blocked oscillating axle. These capacities can be slewed through 360° with the undercarriage in the transverse position. Capacities in the longitudinal position of the undercarriage (±15°) are specified over the steering axle with the stabilizers raised and over the rigid axle with the stabilizers down. Indicated loads based on the ISO 10567 standard and do not exceed 75% of tipping or 87% of hydraulic capacity. The maximum lift capacity for the quick coupler's load hook is 26,500 lb. Without attachment the lift capacity will increase by 7,716 lb and without quick coupler, tipping cylinder, lever and connection link by an additional 1,775 lb. The lift capacity of the unit is limited by its stability, the lifting capability of the hydraulic elements, or the maximum permissible lifting capacity of the load hook.

LH 30 M – Equipment GSV13

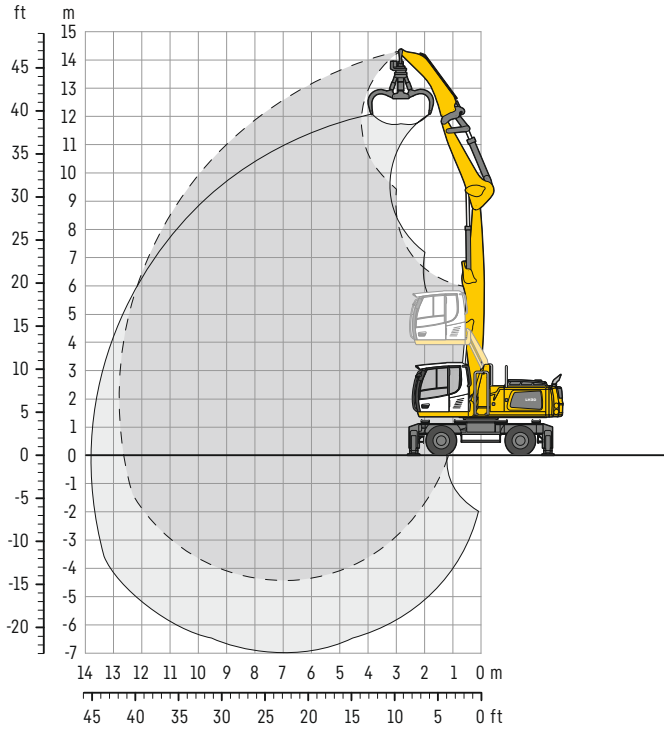

Dimensions

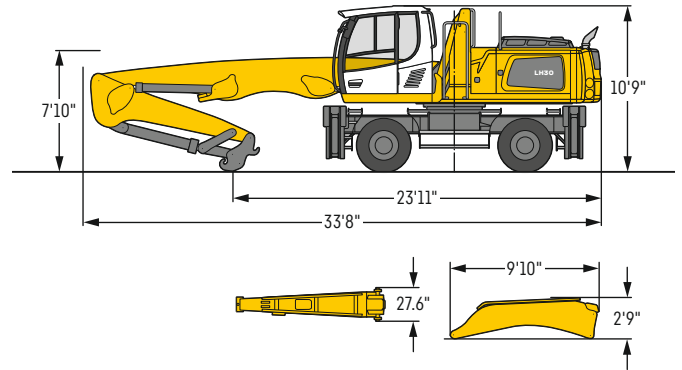

Operating weight

The operating weight includes the basic machine with 4 point outriggers, hydr. cab elevation, 8 solid tires plus intermediate rings, straight boom 22'4", stick HD with tipping kinematics special 10'6", quick coupler SWA 48, stick extension 8'10" and multi-tine grab GM 65 / 0.78 yd³ semi-closed tines.

Weight 66,100 lb

A heavy counterweight (13,400 lb) is required for this attachment configuration.

ft	Undercarriage	10ft		15ft		20ft		25ft		30ft		35ft		40ft		45ft		ft in		
		Stabilizers raised	4 pt. outriggers down	Stabilizers raised	4 pt. outriggers down	Stabilizers raised	4 pt. outriggers down	Stabilizers raised	4 pt. outriggers down	Stabilizers raised	4 pt. outriggers down	Stabilizers raised	4 pt. outriggers down	Stabilizers raised	4 pt. outriggers down	Stabilizers raised	4 pt. outriggers down			
45	Stabilizers raised			14,3*	14,3*													12,3*	12,3*	16'11"
	4 pt. outriggers down			14,3*	14,3*													12,3*	12,3*	
40	Stabilizers raised					13,8*	13,8*	9,3	9,8*									8,8	9,0*	25' 7"
	4 pt. outriggers down					13,8*	13,8*	9,8*	9,8*									9,0*	9,0*	
35	Stabilizers raised					14,9*	14,9*	10,0	13,0*	6,7	9,1							6,0	7,6*	31' 2"
	4 pt. outriggers down					14,9*	14,9*	13,0*	13,0*	9,3*	9,3*							7,6*	7,6*	
30	Stabilizers raised							10,2	12,6*	7,0	9,4	4,7	6,6					4,6	6,5	35' 2"
	4 pt. outriggers down							12,6*	12,6*	11,1*	11,1*	7,3*	7,3*					6,9*	6,9*	
25	Stabilizers raised							10,1	12,6*	6,9	9,3	4,8	6,7					3,7	5,5	38' 1"
	4 pt. outriggers down							12,6*	12,6*	11,0*	11,0*	9,6*	9,6*					6,5*	6,5*	
20	Stabilizers raised					14,5	15,2*	9,6	12,8	6,7	9,1	4,7	6,6	3,2	4,8			3,2	4,8	40' 2"
	4 pt. outriggers down					15,2*	15,2*	12,9*	12,9*	11,1*	11,1*	9,6*	9,6*	6,6*	6,6*			6,3*	6,3*	
15	Stabilizers raised					13,4	16,2*	9,0	12,1	6,3	8,6	4,5	6,4	3,1	4,8			2,8	4,3	41' 6"
	4 pt. outriggers down					16,2*	16,2*	13,4*	13,4*	11,3*	11,3*	9,5*	9,5*	7,8	7,8*			6,2*	6,2*	
10	Stabilizers raised	15,0*	15,0*	19,2	22,9*	12,0	16,3	8,1	11,2	5,7	8,1	4,1	6,1	3,0	4,6			2,6	4,1	42' 2"
	4 pt. outriggers down	15,0*	15,0*	22,9*	22,9*	17,3*	17,3*	13,8*	13,8*	11,4*	11,4*	9,4*	9,4*	7,5*	7,5*			6,3*	6,3*	
5	Stabilizers raised	19,2*	19,2*	16,0	22,9	10,4	14,6	7,2	10,2	5,2	7,5	3,8	5,7	2,8	4,4			2,5	4,0	42' 4"
	4 pt. outriggers down	19,2*	19,2*	25,0*	25,0*	18,1*	18,1*	14,1*	14,1*	11,3*	11,3*	9,2*	9,2*	7,0*	7,0*			5,7*	5,7*	
0	Stabilizers raised	7,4*	7,4*	13,5	20,1	9,0	13,1	6,4	9,4	4,7	7,0	3,5	5,4	2,7	4,3			2,5	4,0	41'10"
	4 pt. outriggers down	7,4*	7,4*	25,0*	25,0*	18,0*	18,0*	13,8*	13,8*	10,9*	10,9*	8,5*	8,5*	6,1*	6,1*			4,8*	4,8*	
-5	Stabilizers raised	8,3*	8,3*	12,2	18,6	8,1	12,2	5,8	8,8	4,4	6,6	3,3	5,2	2,6	4,2			2,6	4,0*	40' 6"
	4 pt. outriggers down	8,3*	8,3*	21,3*	21,3*	16,6*	16,6*	12,7*	12,7*	9,8*	9,8*	7,4*	7,4*	4,4*	4,4*			4,0*	4,0*	
-10	Stabilizers raised	10,5*	10,5*	11,7	18,0*	7,7	11,7	5,5	8,4	4,2	6,4	3,3	5,1					3,1	4,6*	36' 2"
	4 pt. outriggers down	10,5*	10,5*	18,0*	18,0*	13,8*	13,8*	10,6*	10,6*	8,0*	8,0*	5,3*	5,3*					4,6*	4,6*	
-15	Stabilizers raised																			
	4 pt. outriggers down																			

Height Can be slewed through 360° In longitudinal position of undercarriage Max. reach * Limited by hydr. capacity

The lift capacities on the end of the stick extension without attachment are stated in lb x 1,000 and are valid on a firm, level supporting surface with blocked oscillating axle. These capacities can be slewed through 360° with the undercarriage in the transverse position. Capacities in the longitudinal position of the undercarriage (±15°) are specified over the steering axle with the stabilizers raised and over the rigid axle with the stabilizers down. Indicated loads based on the ISO 10567 standard and do not exceed 75% of tipping or 87% of hydraulic capacity. The lift capacity of the unit is limited by its stability, the lifting capability of the hydraulic elements, or the maximum permissible lifting capacity of the load hook.

LH 30 M – Equipment GK12

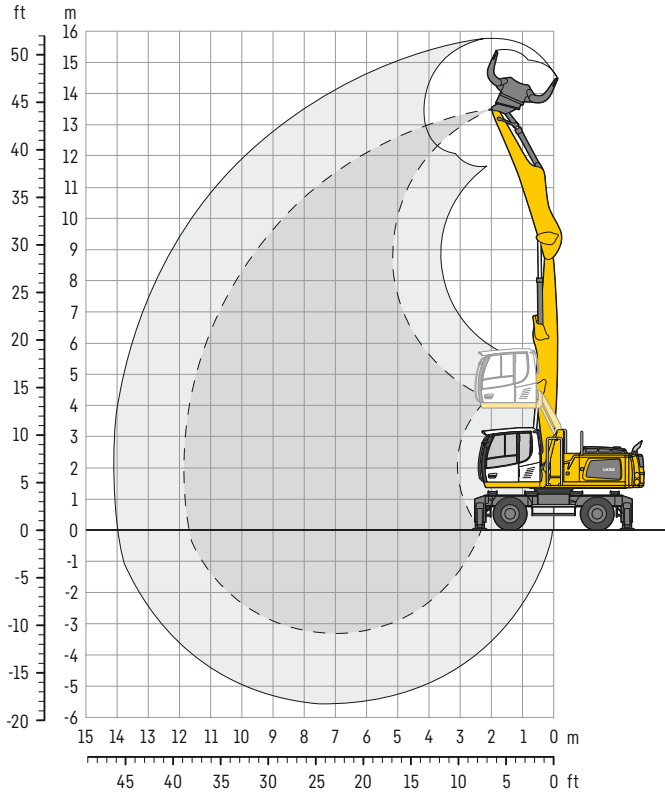

Dimensions

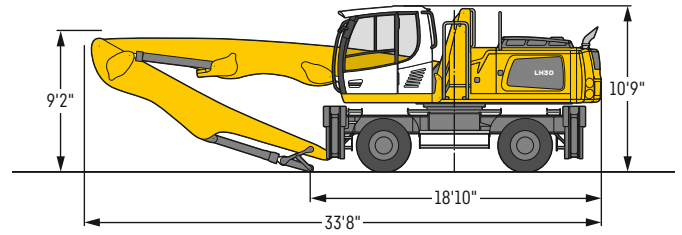

Operating weight

The operating weight includes the basic machine with 4 point outriggers, hydr. cab elevation, 8 solid tires plus intermediate rings, straight boom 22'4", stick with tipping kinematics 16'5" and sorting grab SG 30B /1.11yd³ perforated shells.

Weight 64,200 lb

ft	Undercarriage	10ft		15ft		20ft		25ft		30ft		35ft		40ft		45ft		ft in	
		☐	☒	☐	☒	☐	☒	☐	☒	☐	☒	☐	☒	☐	☒	☐	☒		
45	Stabilizers raised																		
45	4 pt. outriggers down																		
40	Stabilizers raised			18,7	19,2*													12,0	14,0*
40	4 pt. outriggers down			19,2*	19,2*													14,0*	14,0*
35	Stabilizers raised					12,2	16,2	8,0	10,8									7,1	9,7
35	4 pt. outriggers down					12,2*	17,2*	13,6*	13,6*									11,1*	11,1*
30	Stabilizers raised					12,4	16,5	8,3	11,2	5,7	7,8							5,3	7,3
30	4 pt. outriggers down					16,7*	16,7*	14,5*	14,5*	12,0*	12,0*							9,8*	9,8*
25	Stabilizers raised					12,3	16,4	8,3	11,1	5,8	8,0							4,3	6,1
25	4 pt. outriggers down					16,8*	16,8*	14,4*	14,4*	12,2	12,6*							9,1*	9,1*
20	Stabilizers raised			19,1	19,6*	11,8	15,8	8,0	10,9	5,7	7,9	4,1	5,8					3,7	5,3
20	4 pt. outriggers down			19,6*	19,6*	17,5*	17,5*	14,7*	14,7*	12,0	12,6*	9,1	10,7*					8,4	8,7*
15	Stabilizers raised	15,5*	15,5*	17,5	23,9*	11,0	15,0	7,6	10,4	5,4	7,6	4,0	5,7					3,3	4,9
15	4 pt. outriggers down	15,5*	15,5*	23,9*	23,9*	18,6*	18,6*	15,2*	15,2*	11,8	12,7*	9,0	10,6*					7,8	8,6*
10	Stabilizers raised	28,5	28,8*	15,4	21,8	10,0	13,9	7,0	9,8	5,1	7,3	3,8	5,6					3,1	4,6
10	4 pt. outriggers down	28,8*	28,8*	26,7*	26,7*	19,7*	19,7*	15,3	15,6*	11,4	12,8*	8,9	10,4*					7,5	8,2*
5	Stabilizers raised			13,4	19,5	9,0	12,8	6,5	9,2	4,8	6,9	3,7	5,4					3,0	4,5
5	4 pt. outriggers down			27,8*	27,8*	20,2*	20,2*	14,6	15,6*	11,0	12,5*	8,7	9,9*					7,2*	7,2*
0	Stabilizers raised	3,7*	3,7*	12,2	17,4*	8,3	12,0	6,0	8,7	4,6	6,7	3,5	5,3					3,1	4,6
0	4 pt. outriggers down	3,7*	3,7*	17,4*	17,4*	19,3*	19,3*	14,1	14,9*	10,8	11,7*	8,5	8,8*					6,1*	6,1*
-5	Stabilizers raised			11,7	17,3*	7,9	11,6	5,7	8,4	4,4	6,5	3,5	5,2					3,4	5,1
-5	4 pt. outriggers down			17,3*	17,3*	16,9*	16,9*	13,2*	13,2*	10,0*	10,0*	6,8*	6,8*					6,2*	6,2*
-10	Stabilizers raised			7,8	11,5	5,7	8,4											4,7	7,0
-10	4 pt. outriggers down			13,0*	13,0*	10,2*	10,2*											8,2*	8,2*

☐ Height ☐ Can be slewed through 360° ☒ In longitudinal position of undercarriage ☐ Max. reach * Limited by hydr. capacity

The lift capacities on the stick end without attachment are stated in lb x 1,000 and are valid on a firm, level supporting surface with blocked oscillating axle. These capacities can be slewed through 360° with the undercarriage in the transverse position. Capacities in the longitudinal position of the undercarriage (± 15°) are specified over the steering axle with the stabilizers raised and over the rigid axle with the stabilizers down. Indicated loads based on the ISO 10567 standard and do not exceed 75% of tipping or 87% of hydraulic capacity. The lift capacity of the unit is limited by its stability, the lifting capability of the hydraulic elements, or the maximum permissible lifting capacity of the load hook.

LH 35 M – Equipment GK13

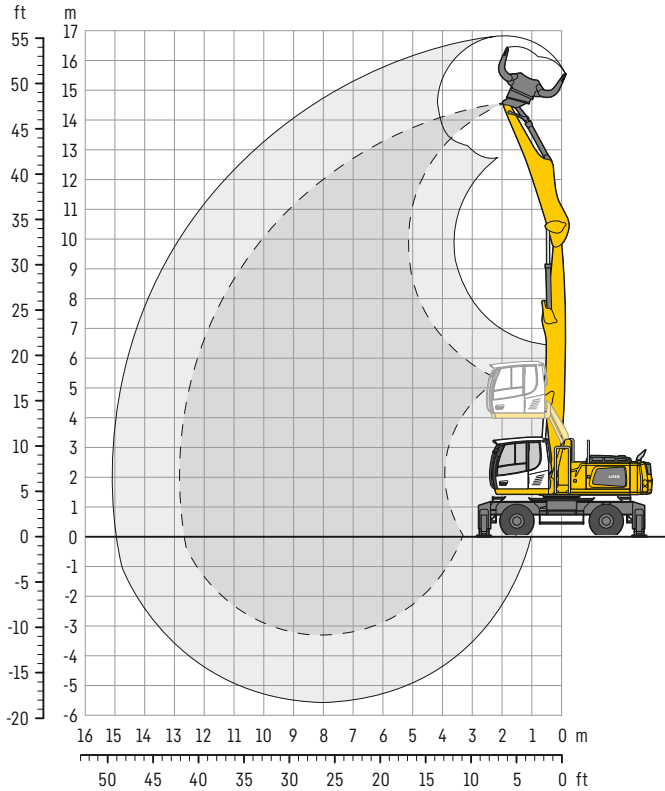

Dimensions

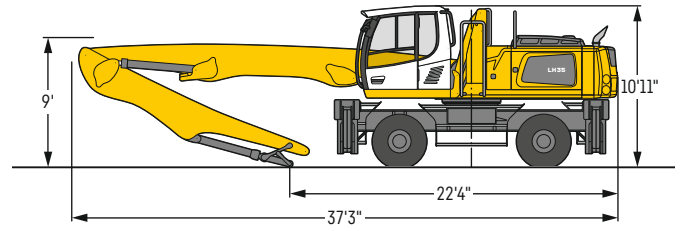

Operating weight

The operating weight includes the basic machine with 4 point outriggers, hydr. cab elevation, 8 solid tires plus intermediate rings, straight boom 25'7", stick with tipping kinematics 16'5" and sorting grab SG 30B / 1.11yd³ perforated shells.

Weight 73,900 lb

ft	Undercarriage	10ft		15ft		20ft		25ft		30ft		35ft		40ft		45ft		ft in		
		☐	☒	☐	☒	☐	☒	☐	☒	☐	☒	☐	☒	☐	☒	☐	☒	☐	☒	
45	Stabilizers raised			18,4*	18,4*													16,0*	16,0*	16'11"
	4 pt. outriggers down			18,4*	18,4*													16,0*	16,0*	
40	Stabilizers raised					16,3	17,1*	10,9	13,0*									10,4	11,9*	25' 7"
	4 pt. outriggers down					17,1*	17,1*	13,0*	13,0*									11,9*	11,9*	
35	Stabilizers raised					16,5*	16,5*	11,5	14,0*	8,1	10,5							7,5	9,7	31' 1"
	4 pt. outriggers down					16,5*	16,5*	14,0*	14,0*	12,1*	12,1*							10,2*	10,2*	
30	Stabilizers raised					16,4*	16,4*	11,5	13,9*	8,3	10,7	6,0	7,9					6,0	7,9	35' 1"
	4 pt. outriggers down					16,4*	16,4*	13,9*	13,9*	12,0*	12,0*	9,6*	9,6*					9,4*	9,4*	
25	Stabilizers raised					16,3	16,8*	11,3	14,0*	8,2	10,6	6,1	8,0					5,1	6,8	38'
	4 pt. outriggers down					16,8*	16,8*	14,0*	14,0*	12,0*	12,0*	10,3*	10,3*					8,9*	8,9*	
20	Stabilizers raised			21,2*	21,2*	15,5	17,7*	10,8	14,0	8,0	10,3	6,0	7,9	4,5	6,1			4,5	6,1	40'
	4 pt. outriggers down			21,2*	21,2*	17,7*	17,7*	14,4*	14,4*	12,1*	12,1*	10,3*	10,3*	8,3*	8,3*			8,3*	8,3*	
15	Stabilizers raised	38,5*	38,5*	22,2	25,0*	14,4	18,7*	10,2	13,3	7,6	10,0	5,8	7,7	4,5	6,1			4,2	5,7	41' 4"
	4 pt. outriggers down	38,5*	38,5*	25,0*	25,0*	18,7*	18,7*	14,8*	14,8*	12,2*	12,2*	10,2*	10,2*	8,3*	8,3*			7,5*	7,5*	
10	Stabilizers raised			19,5	26,6*	13,1	17,4	9,5	12,5	7,2	9,5	5,6	7,5	4,4	6,0			4,0	5,5	42'
	4 pt. outriggers down			26,6*	26,6*	19,3*	19,3*	15,1*	15,1*	12,2*	12,2*	10,0*	10,0*	7,9*	7,9*			6,7*	6,7*	
5	Stabilizers raised			7,4*	7,4*	12,0	16,2	8,9	11,9	6,8	9,1	5,4	7,2	4,3	5,9			3,9	5,4	42' 1"
	4 pt. outriggers down			7,4*	7,4*	19,0*	19,0*	14,8*	14,8*	11,8*	11,8*	9,5*	9,5*	7,3*	7,3*			5,9*	5,9*	
0	Stabilizers raised			7,2*	7,2*	11,3	15,5	8,4	11,4	6,5	8,8	5,2	7,0	4,2	5,8			4,0	4,9*	41' 6"
	4 pt. outriggers down			7,2*	7,2*	17,5*	17,5*	13,8*	13,8*	11,0*	11,0*	8,6*	8,6*	6,1*	6,1*			4,9*	4,9*	
-5	Stabilizers raised			9,7*	9,7*	11,0	14,7*	8,1	11,1	6,3	8,6	5,1	6,9					4,4	5,0*	38'11"
	4 pt. outriggers down			9,7*	9,7*	14,7*	14,7*	11,9*	11,9*	9,5*	9,5*	7,2*	7,2*					5,0*	5,0*	
-10	Stabilizers raised					8,1	9,2*	6,3	7,2*	6,3	7,2*							5,9	6,6*	31' 5"
	4 pt. outriggers down					9,2*	9,2*	7,2*	7,2*	7,2*	7,2*							6,6*	6,6*	

☐ Height ☐ Can be slewed through 360° ☒ In longitudinal position of undercarriage ☐ Max. reach * Limited by hydr. capacity

The lift capacities on the stick end without attachment are stated in lb x 1,000 and are valid on a firm, level supporting surface with blocked oscillating axle. These capacities can be slewed through 360° with the undercarriage in the transverse position. Capacities in the longitudinal position of the undercarriage (± 15°) are specified over the steering axle with the stabilizers raised and over the rigid axle with the stabilizers down. Indicated loads based on the ISO 10567 standard and do not exceed 75% of tipping or 87% of hydraulic capacity. The lift capacity of the unit is limited by its stability, the lifting capability of the hydraulic elements, or the maximum permissible lifting capacity of the load hook.

LH 35 M – Equipment GA14

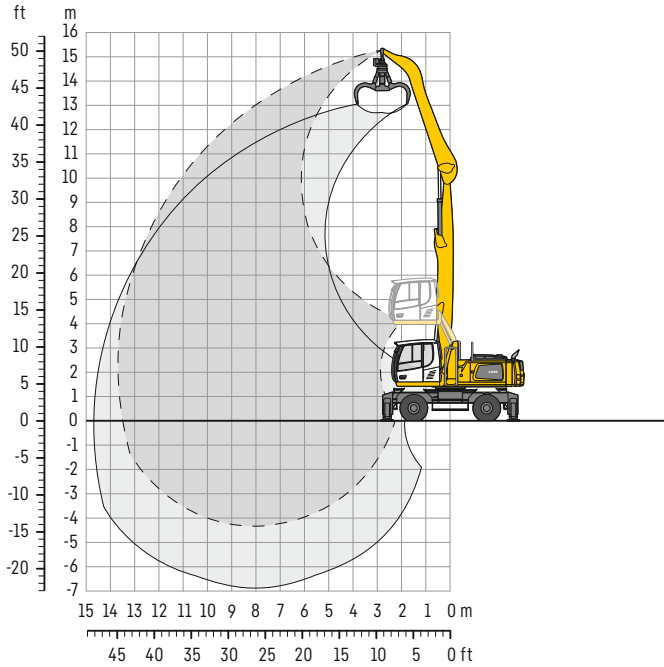

Dimensions

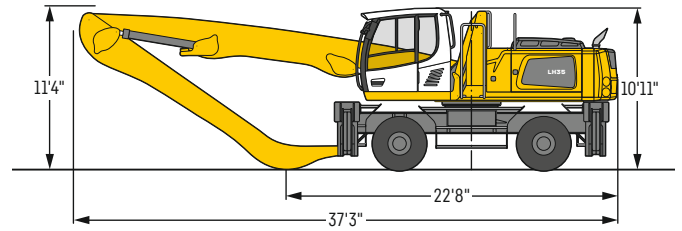

Operating weight

The operating weight includes the basic machine with 4 point outriggers, hydr. cab elevation, 8 solid tires plus intermediate rings, straight boom 25'7", angled stick 19'8" and multi-tine grab GM 65 / 0.78 yd³ semi-closed tines.

Weight 73,000 lb

ft	Undercarriage	10ft		15ft		20ft		25ft		30ft		35ft		40ft		45ft		Stick		ft in
		Can be slewed through 360°	In longitudinal position of undercarriage	Can be slewed through 360°	In longitudinal position of undercarriage	Can be slewed through 360°	In longitudinal position of undercarriage	Can be slewed through 360°	In longitudinal position of undercarriage	Can be slewed through 360°	In longitudinal position of undercarriage	Can be slewed through 360°	In longitudinal position of undercarriage	Can be slewed through 360°	In longitudinal position of undercarriage	Can be slewed through 360°	In longitudinal position of undercarriage	Can be slewed through 360°	In longitudinal position of undercarriage	
50	Stabilizers raised 4 pt. outriggers down	17,8* 17,8*	17,8* 17,8*															17,6* 17,6*	17,6* 17,6*	10' 1"
45	Stabilizers raised 4 pt. outriggers down					13,8* 13,8*	13,8* 13,8*											11,0* 11,0*	11,0* 11,0*	23'
40	Stabilizers raised 4 pt. outriggers down					15,8* 15,8*	15,8* 15,8*	12,4 13,6*	12,4 13,6*									8,9 9,3*	9,3* 9,3*	29'11"
35	Stabilizers raised 4 pt. outriggers down							12,7 13,7*	13,7* 13,7*	9,3 12,2*	11,7 12,2*							6,9 8,4*	8,4* 8,4*	34'10"
30	Stabilizers raised 4 pt. outriggers down							12,6 13,7*	13,7* 13,7*	9,3 12,1*	11,7 12,1*	7,1 10,7*	9,0 10,7*					5,8 7,9*	7,9* 7,9*	38' 4"
25	Stabilizers raised 4 pt. outriggers down					16,2* 16,2*	16,2* 16,2*	12,4 13,9*	13,9* 13,9*	9,2 12,2*	11,6 12,2*	7,0 10,7*	8,9 10,7*	5,4 9,3*	7,0 9,3*			5,1 7,6*	6,9* 7,6*	41'
20	Stabilizers raised 4 pt. outriggers down					16,9 17,1*	17,1* 17,1*	11,9 14,4*	14,4* 14,4*	8,9 12,4*	11,3 12,4*	6,9 10,8*	8,8 10,8*	5,4 9,3*	7,0 9,3*			4,7 7,5*	6,1 7,5*	42'11"
15	Stabilizers raised 4 pt. outriggers down	15,4* 15,4*	15,4* 15,4*	22,3* 22,3*	22,3* 22,3*	15,8 18,3*	18,3* 18,3*	11,3 15,0*	14,4 15,0*	8,5 12,6*	10,9 12,6*	6,6 10,8*	8,5 10,8*	5,2 9,2*	6,8 9,2*			4,4 7,5*	5,7 7,5*	44' 1"
10	Stabilizers raised 4 pt. outriggers down	16,2* 16,2*	16,2* 16,2*	21,7 26,3*	26,3* 26,3*	14,5 19,5*	18,8 19,5*	10,5 15,5*	13,6 15,5*	8,0 12,8*	10,4 12,8*	6,3 10,8*	8,2 10,8*	5,1 9,0*	6,7 9,0*			4,2 7,1*	5,5 7,1*	44'10"
5	Stabilizers raised 4 pt. outriggers down	2,6* 2,6*	2,6* 2,6*	19,2 21,2*	21,2* 21,2*	13,2 19,9*	17,4 19,9*	9,8 15,6*	12,8 15,6*	7,6 12,7*	9,9 12,7*	6,0 10,5*	7,9 10,5*	4,9 8,6*	6,5 8,6*			4,1 6,4*	5,5 6,4*	44'10"
0	Stabilizers raised 4 pt. outriggers down	3,7* 3,7*	3,7* 3,7*	12,3* 12,3*	12,3* 12,3*	12,2 19,2*	16,4 19,2*	9,2 15,1*	12,1 15,1*	7,2 12,2*	9,5 12,2*	5,8 10,0*	7,7 10,0*	4,8 7,9*	6,3 7,9*			4,1 5,7*	5,5 5,7*	44' 4"
- 5	Stabilizers raised 4 pt. outriggers down	5,9* 5,9*	5,9* 5,9*	12,1* 12,1*	12,1* 12,1*	11,6 17,3*	15,8 17,3*	8,7 13,8*	11,7 13,8*	6,9 11,1*	9,2 11,1*	5,6 8,9*	7,5 8,9*	4,7 6,7*	6,3 6,7*			4,3 5,0*	5,0* 5,0*	42'11"
-10	Stabilizers raised 4 pt. outriggers down			13,8* 13,8*	13,8* 13,8*	11,4 14,3*	14,3* 14,3*	8,6 11,7*	11,5 11,7*	6,8 9,4*	9,1* 9,4*	5,6 7,2*	7,2* 7,2*					5,0 5,7*	5,7* 5,7*	38' 5"
-15	Stabilizers raised 4 pt. outriggers down																			

Height Can be slewed through 360° In longitudinal position of undercarriage Max. reach * Limited by hydr. capacity

The lift capacities on the stick end without attachment are stated in lb x 1,000 and are valid on a firm, level supporting surface with blocked oscillating axle. These capacities can be slewed through 360° with the undercarriage in the transverse position. Capacities in the longitudinal position of the undercarriage (± 15°) are specified over the steering axle with the stabilizers raised and over the rigid axle with the stabilizers down. Indicated loads based on the ISO 10567 standard and do not exceed 75% of tipping or 87% of hydraulic capacity. The lift capacity of the unit is limited by its stability, the lifting capability of the hydraulic elements, or the maximum permissible lifting capacity of the load hook.

LH 35 M – Equipment GA15

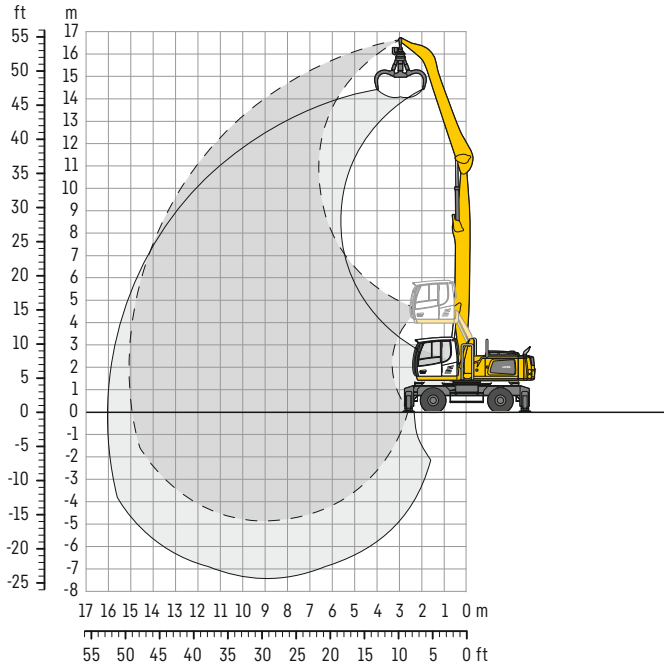

Dimensions

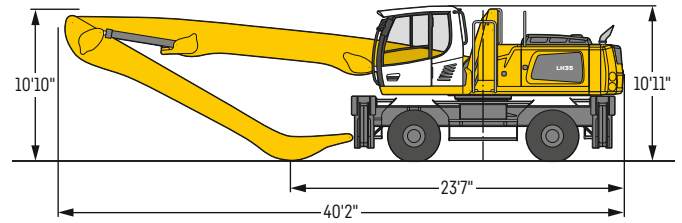

Operating weight

The operating weight includes the basic machine with 4 point outriggers, hydr. cab elevation, 8 solid tires plus intermediate rings, straight boom 28'7\", angled stick 21'4\" and multi-tine grab GM 65 / 0.78 yd³ semi-closed tines.

Weight 73,900 lb

ft	Undercarriage	10ft		15ft		20ft		25ft		30ft		35ft		40ft		45ft		ft in		
		Stabilizers raised	4 pt. outriggers down	Stabilizers raised	4 pt. outriggers down	Stabilizers raised	4 pt. outriggers down	Stabilizers raised	4 pt. outriggers down	Stabilizers raised	4 pt. outriggers down	Stabilizers raised	4 pt. outriggers down	Stabilizers raised	4 pt. outriggers down	Stabilizers raised	4 pt. outriggers down			
50	Stabilizers raised					13.1*	13.1*											10.6*	10.6*	23' 4"
	4 pt. outriggers down					13.1*	13.1*											10.6*	10.6*	
45	Stabilizers raised					14.7*	14.7*	12.5	13.0*	8.9	9.8*							8.3	8.8*	31'
	4 pt. outriggers down					14.7*	14.7*	13.0*	13.0*	9.8*	9.8*							8.8*	8.8*	
40	Stabilizers raised					12.9	13.1*	12.9	13.1*	9.4	11.4*	6.9	8.8					6.3	7.8*	36' 5"
	4 pt. outriggers down					13.1*	13.1*	13.1*	13.1*	11.4*	11.4*	9.4*	9.4*					7.8*	7.8*	
35	Stabilizers raised					13.0	13.0*	13.0	13.0*	9.5	11.3*	7.1	9.0	5.3	6.9			5.1	6.7	40' 6"
	4 pt. outriggers down					13.0*	13.0*	13.0*	13.0*	11.3*	11.3*	10.0*	10.0*	8.0*	8.0*			7.3*	7.3*	
30	Stabilizers raised					12.8	13.1*	12.8	13.1*	9.4	11.3*	7.1	9.0	5.4	7.0			4.4	5.8	43' 7"
	4 pt. outriggers down					13.1*	13.1*	13.1*	13.1*	11.3*	11.3*	10.0*	10.0*	8.8*	8.8*			7.0*	7.0*	
25	Stabilizers raised					15.9*	15.9*	12.4	13.4*	9.1	11.5*	6.9	8.8	5.3	6.9	4.1	5.4	3.9	5.2	45' 11"
	4 pt. outriggers down					15.9*	15.9*	13.4*	13.4*	11.5*	11.5*	10.0*	10.0*	8.8*	8.8*	7.5*	7.5*	6.8*	6.8*	
20	Stabilizers raised					16.7	16.8*	11.7	13.8*	8.7	11.1	6.6	8.6	5.2	6.8	4.0	5.4	3.5	4.8	47' 7"
	4 pt. outriggers down					16.8*	16.8*	13.8*	13.8*	11.7*	11.7*	10.1*	10.1*	8.8*	8.8*	7.5*	7.5*	6.7*	6.7*	
15	Stabilizers raised	15.9*	15.9*	23.0*	23.0*	15.3	17.8*	10.8	14.0	8.1	10.5	6.3	8.2	4.9	6.5	3.9	5.3	3.3	4.5	48' 8"
	4 pt. outriggers down	15.9*	15.9*	23.0*	23.0*	17.8*	17.8*	14.3*	14.3*	11.9*	11.9*	10.2*	10.2*	8.7*	8.7*	7.4*	7.4*	6.2*	6.2*	
10	Stabilizers raised			20.2	25.5*	13.6	17.9	9.9	12.9	7.5	9.9	5.9	7.8	4.7	6.3	3.8	5.1	3.1	4.4	49' 4"
	4 pt. outriggers down			25.5*	25.5*	18.7*	18.7*	14.7*	14.7*	12.0*	12.0*	10.1*	10.1*	8.6*	8.6*	7.1*	7.1*	5.6*	5.6*	
5	Stabilizers raised			9.7*	9.7*	12.0	16.3	9.0	12.0	6.9	9.3	5.5	7.4	4.4	6.0	3.6	5.0	3.1	4.3	49' 4"
	4 pt. outriggers down			9.7*	9.7*	18.7*	18.7*	14.6*	14.6*	11.9*	11.9*	9.9*	9.9*	8.3*	8.3*	6.7*	6.7*	5.1*	5.1*	
0	Stabilizers raised	1.7*	1.7*	7.2*	7.2*	10.9	15.1	8.2	11.2	6.4	8.7	5.2	7.1	4.2	5.8	3.5	4.9	3.1	4.3	48' 11"
	4 pt. outriggers down	1.7*	1.7*	7.2*	7.2*	17.8*	17.8*	14.1*	14.1*	11.4*	11.4*	9.4*	9.4*	7.7*	7.7*	6.1*	6.1*	4.4*	4.4*	
-5	Stabilizers raised			8.0*	8.0*	10.3	14.4	7.7	10.7	6.1	8.4	4.9	6.8	4.1	5.6	3.4	4.8	3.2	3.7*	47' 11"
	4 pt. outriggers down			8.0*	8.0*	15.8*	15.8*	12.8*	12.8*	10.5*	10.5*	8.6*	8.6*	6.9*	6.9*	5.1*	5.1*	3.7*	3.7*	
-10	Stabilizers raised			9.6*	9.6*	10.0	13.0*	7.5	10.4	5.9	8.2	4.8	6.7	4.0	5.6			3.5	4.1*	44'
	4 pt. outriggers down			9.6*	9.6*	13.0*	13.0*	10.9*	10.9*	9.0*	9.0*	7.3*	7.3*	5.6*	5.6*			4.1*	4.1*	
-15	Stabilizers raised					7.4	8.3*	5.8	6.9*	5.8	6.9*	4.8	5.4*					4.7	5.3*	35' 5"
	4 pt. outriggers down					8.3*	8.3*	6.9*	6.9*	6.9*	6.9*	5.4*	5.4*					5.3*	5.3*	

Height Can be slewed through 360° In longitudinal position of undercarriage Max. reach * Limited by hydr. capacity

The lift capacities on the stick end without attachment are stated in lb x 1,000 and are valid on a firm, level supporting surface with blocked oscillating axle. These capacities can be slewed through 360° with the undercarriage in the transverse position. Capacities in the longitudinal position of the undercarriage (± 15°) are specified over the steering axle with the stabilizers raised and over the rigid axle with the stabilizers down. Indicated loads based on the ISO 10567 standard and do not exceed 75% of tipping or 87% of hydraulic capacity. The lift capacity of the unit is limited by its stability, the lifting capability of the hydraulic elements, or the maximum permissible lifting capacity of the load hook.

LH 30 C LC – Equipment GK10

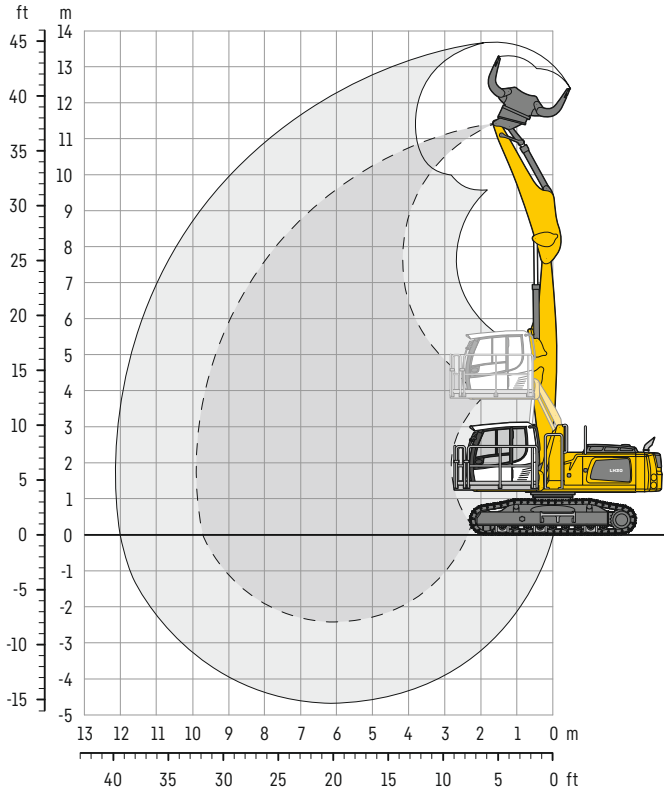

Dimensions

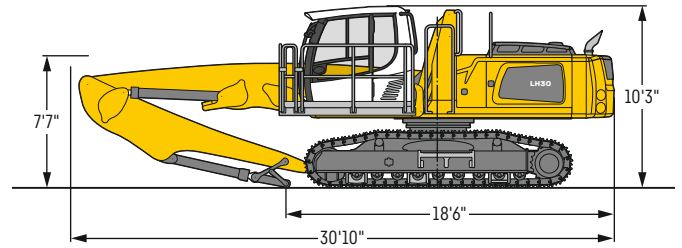

Operating weight and ground pressure

The operating weight includes the basic machine with hydr. cab elevation, straight boom 19', stick with tipping kinematics 13'1" and sorting grab SG 30B / 1.11yd³ perforated shells.

Weight	65,300 lb
Pad width	24"
Ground pressure	on request

ft	Undercarriage	10ft		15ft		20ft		25ft		30ft		35ft		40ft		45ft		ft in		
35	LC	26,4*	26,4*															20,4*	20,4*	13' 4"
30	LC	00,0*		23,3*	23,3*	16,1	18,3*											14,3	14,6*	21' 4"
25	LC			22,4*	22,4*	16,4	18,9*	11,3	16,2*									10,5	12,6*	26' 1"
20	LC			23,1*	23,1*	16,3	19,1*	11,4	16,2*									8,7	11,7*	29' 1"
15	LC	23,3*	23,3*	24,8	25,1*	15,8	19,9*	11,1	16,5*	8,3	12,9							7,8	11,3*	31' 1"
10	LC	42,6*	42,6*	23,3	27,9*	15,1	20,9*	10,8	16,7*	8,2	12,8							7,3	11,3*	32' 2"
5	LC	6,3*	6,3*	21,7	29,3*	14,3	21,3*	10,4	16,4*	8,0	12,5*							7,1	10,0*	32' 5"
0	LC	7,4*	7,4*	20,7	27,5*	13,8	20,2*	10,1	15,2*	7,9	10,8*							7,3	8,3*	31' 11"
-5	LC			20,3	22,5*	13,5	17,1*	10,0	12,5*									8,5	9,3*	28' 5"

Height Can be slewed through 360° In longitudinal position of undercarriage Max. reach * Limited by hydr. capacity

The lift capacities on the stick end without attachment are stated in lb x 1,000 and can be slewed through 360° on a firm, level supporting surface. Capacities are valid for 24" wide triple grouser pads. Indicated loads based on the ISO 10567 standard and do not exceed 75% of tipping or 87% of hydraulic capacity. The lift capacity of the unit is limited by its stability, the lifting capability of the hydraulic elements, or the maximum permissible lifting capacity of the load hook.

LH 30 C LC – Equipment GA10

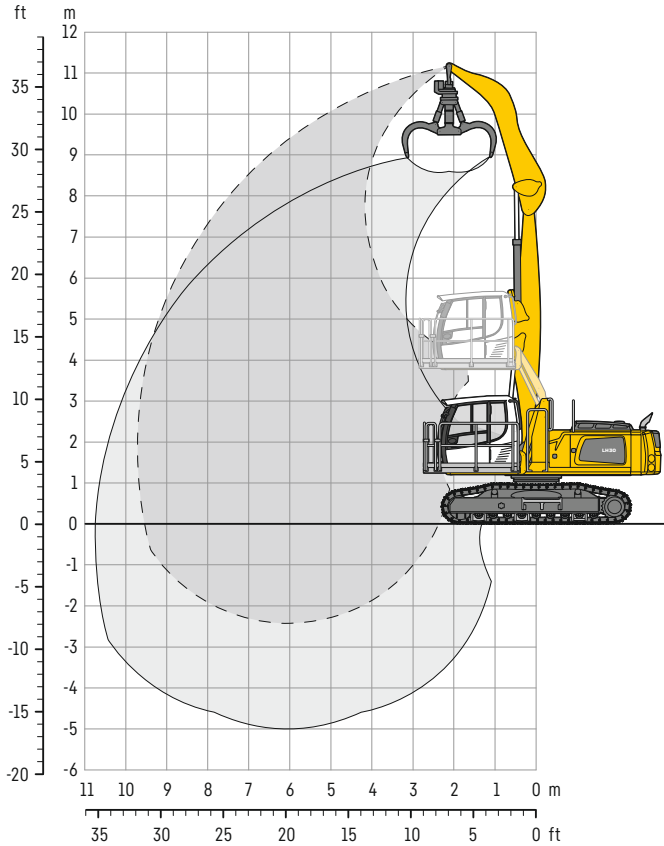

Dimensions

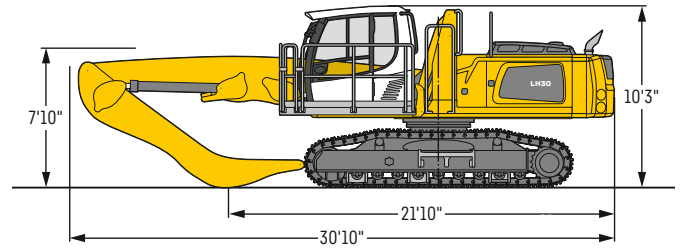

Operating weight and ground pressure

The operating weight includes the basic machine with hydr. cab elevation, straight boom 19', angled stick 13'1" and multi-tine grab GM 65 / 0.78 yd³ semi-closed tines.

Weight	63,100 lb
Pad width	24"
Ground pressure	on request

ft	Undercarriage	10ft		15ft		20ft		25ft		30ft		35ft		40ft		45ft		ft in		
35	LC	23,1*	23,1*															19,7*	19,7*	12'
30	LC			22,6*	22,6*	15,8*	15,8*											14,4*	14,4*	20' 6"
25	LC			23,0*	23,0*	16,9	19,6*	11,8	14,1*									11,5	12,8*	25' 5"
20	LC			23,7*	23,7*	16,8	19,8*	11,9	16,9*									9,6	12,1*	28' 7"
15	LC	29,5*	29,5*	25,3	25,8*	16,3	20,6*	11,7	17,1*	8,8	13,4							8,6	11,9*	30' 7"
10	LC	43,3*	43,3*	23,8	28,6*	15,6	21,6*	11,4	17,4*	8,7	13,3							8,1	12,1*	31' 8"
5	LC	12,0*	12,0*	22,3	30,1*	14,9	22,0*	11,0	17,0	8,6	13,1							7,9	11,4*	31' 11"
0	LC	11,3*	11,3*	21,3	28,3*	14,4	20,9*	10,7	16,0*	8,5	11,5*							8,0	9,9*	31' 4"
-5	LC			21,0	23,3*	14,2	17,8*	10,6	13,3*									9,1	10,0*	28' 5"

Height Can be slewed through 360° In longitudinal position of undercarriage Max. reach * Limited by hydr. capacity

The lift capacities on the stick end without attachment are stated in lb x 1,000 and can be slewed through 360° on a firm, level supporting surface. Capacities are valid for 24" wide triple grouser pads. Indicated loads based on the ISO 10567 standard and do not exceed 75% of tipping or 87% of hydraulic capacity. The lift capacity of the unit is limited by its stability, the lifting capability of the hydraulic elements, or the maximum permissible lifting capacity of the load hook.

LH 30 C EW – Equipment GA12

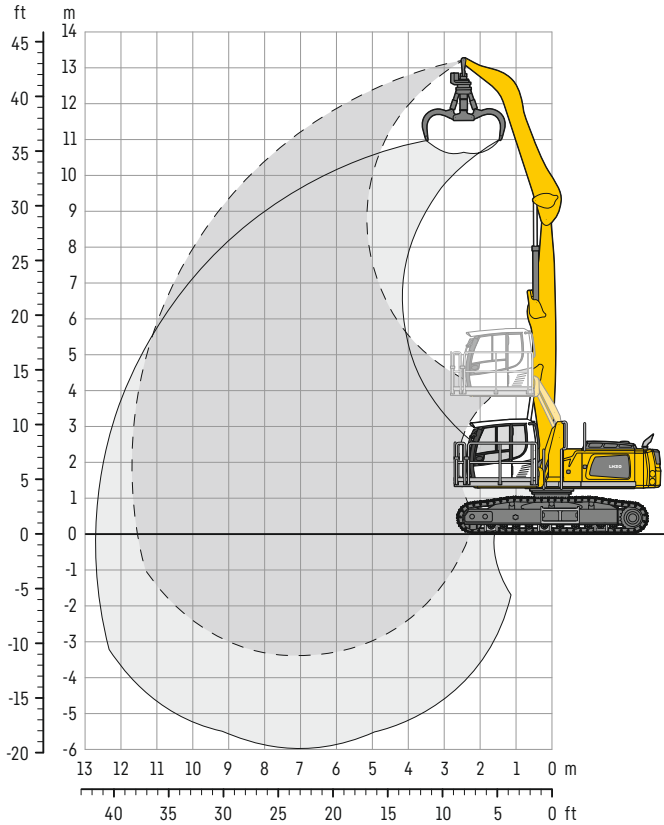

Dimensions

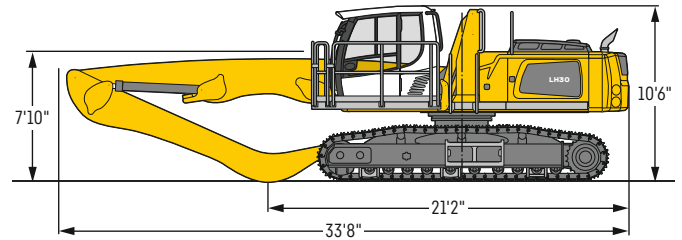

Operating weight and ground pressure

The operating weight includes the basic machine with hydr. cab elevation, straight boom 22'4", angled stick 16'5" and multi-tine grab GM 65 / 0.78 yd³ semi-closed tines.

Weight	67,500 lb
Pad width	24"
Ground pressure	on request

ft	Undercarriage	10ft		15ft		20ft		25ft		30ft		35ft		40ft		45ft		ft in	
45	EW																	14,3* 14,3*	17' 5"
40	EW			17,3*	17,3*													14,3* 14,3*	25' 1"
35	EW					17,2*	17,2*	11,5*	11,5*									11,4* 11,4*	30'
30	EW					17,4*	17,4*	15,2*	15,2*									10,2* 10,2*	33' 5"
25	EW					17,5*	17,5*	15,1*	15,1*	13,3*	13,3*							9,6* 9,6*	35'10"
20	EW			21,7*	21,7*	18,1*	18,1*	15,4*	15,4*	13,4*	13,4*	11,0	11,4*					9,3* 9,3*	37' 5"
15	EW	20,9*	20,9*	24,5*	24,5*	19,3*	19,3*	15,9*	15,9*	13,5*	13,5*	10,9	11,4*					9,3* 9,3*	38' 2"
10	EW	42,1*	42,1*	27,3*	27,3*	20,5*	20,5*	16,4*	16,4*	13,5	13,6*	10,7	11,2*					8,6* 8,6*	37'11"
5	EW	5,7*	5,7*	28,7*	28,7*	21,0*	21,0*	16,5*	16,5*	13,2	13,3*	10,5	10,7*					7,5* 7,5*	36'
0	EW	6,2*	6,2*	21,7*	21,7*	20,3*	20,3*	15,8*	15,8*	12,6*	12,6*	9,7*	9,7*					7,0* 7,0*	29' 5"
-5	EW			19,8*	19,8*	18,1*	18,1*	14,2*	14,2*	11,0*	11,0*	7,8*	7,8*					8,7* 8,7*	
-10	EW					14,3*	14,3*	11,3*	11,3*										

Height Can be slewed through 360° In longitudinal position of undercarriage Max. reach * Limited by hydr. capacity

The lift capacities on the stick end without attachment are stated in lb x 1,000 and can be slewed through 360° on a firm, level supporting surface. Capacities are valid for 24" wide triple grouser pads. Indicated loads based on the ISO 10567 standard and do not exceed 75% of tipping or 87% of hydraulic capacity. The lift capacity of the unit is limited by its stability, the lifting capability of the hydraulic elements, or the maximum permissible lifting capacity of the load hook.

LH 30 C EW – Equipment GA14

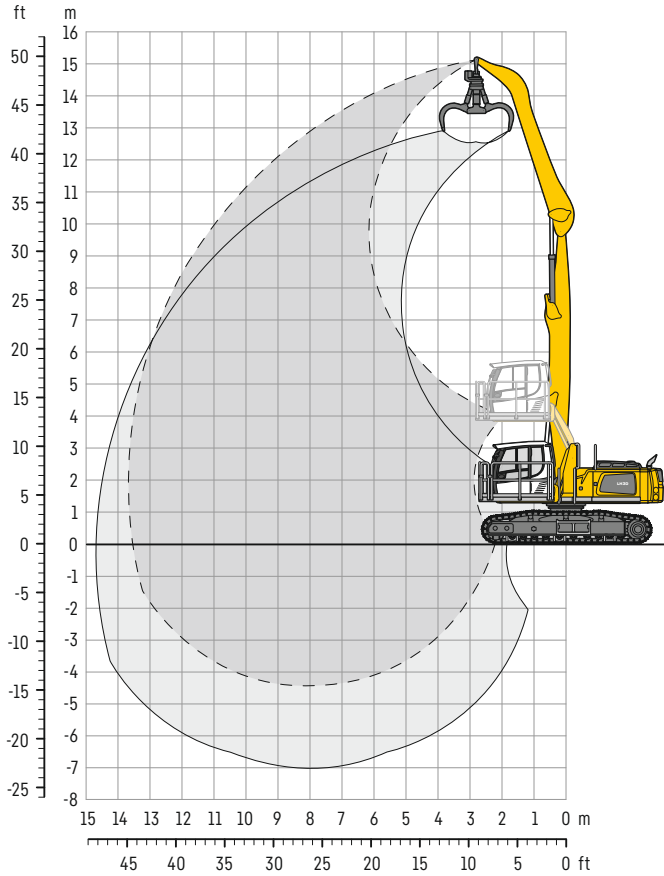

Dimensions

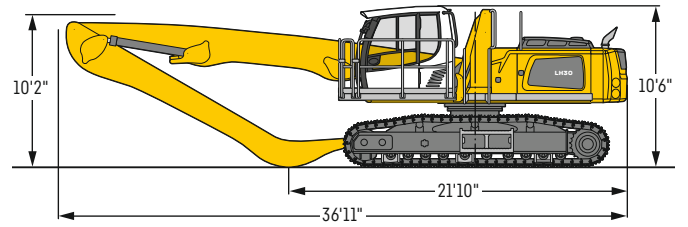

Operating weight and ground pressure

The operating weight includes the basic machine with hydr. cab elevation, straight boom 25'7", angled stick 19'8" and multi-tine grab GM 65 / 0.78 yd³ semi-closed tines.

Weight	68,300 lb
Pad width	24"
Ground pressure	on request

ft	Undercarriage	10ft		15ft		20ft		25ft		30ft		35ft		40ft		45ft		ft in				
45	EW					13,3*	13,3*													11,4*	11,4*	21'10"
40	EW					15,7*	15,7*	13,3*	13,3*											9,4*	9,4*	29' 2"
35	EW					15,9*	15,9*	13,8*	13,8*	12,2*	12,2*									8,5*	8,5*	34' 2"
30	EW							13,7*	13,7*	12,1*	12,1*	10,7*	10,7*							7,9*	7,9*	37'11"
25	EW							16,2*	16,2*	13,9*	13,9*	12,1*	12,1*	10,7*	10,7*	8,8	8,9*			7,6*	7,6*	40' 8"
20	EW							17,0*	17,0*	14,3*	14,3*	12,3*	12,3*	10,8*	10,8*	8,8	9,3*			7,5*	7,5*	42' 8"
15	EW					21,0*	21,0*	18,2*	18,2*	14,9*	14,9*	12,6*	12,6*	10,8*	10,8*	8,7	9,2*			7,4	7,5*	44'
10	EW	40,4*	40,4*	26,0*	26,0*	19,3*	19,3*	15,4*	15,4*	12,8*	12,8*	10,5	10,8*	8,5	9,1*					7,1	7,2*	44' 8"
5	EW	2,8*	2,8*	25,4*	25,4*	19,9*	19,9*	15,6*	15,6*	12,7	12,7*	10,1	10,6*	8,3	8,7*					6,5*	6,5*	44'10"
0	EW	3,4*	3,4*	12,6*	12,6*	19,4*	19,4*	15,2*	15,2*	12,3	12,3*	9,9	10,0*	8,0*	8,0*					5,8*	5,8*	44' 5"
- 5	EW	5,6*	5,6*	12,0*	12,0*	17,6*	17,6*	14,0*	14,0*	11,3*	11,3*	9,1*	9,1*	6,9*	6,9*					4,9*	4,9*	43' 4"
-10	EW			13,5*	13,5*	14,7*	14,7*	12,0*	12,0*	9,7*	9,7*	7,5*	7,5*							5,5*	5,5*	39' 2"

Height Can be slewed through 360° In longitudinal position of undercarriage Max. reach * Limited by hydr. capacity

The lift capacities on the stick end without attachment are stated in lb x 1,000 and can be slewed through 360° on a firm, level supporting surface. Capacities are valid for 24" wide triple grouser pads. Indicated loads based on the ISO 10567 standard and do not exceed 75% of tipping or 87% of hydraulic capacity. The lift capacity of the unit is limited by its stability, the lifting capability of the hydraulic elements, or the maximum permissible lifting capacity of the load hook.

LH 30 C EW – Equipment GK12

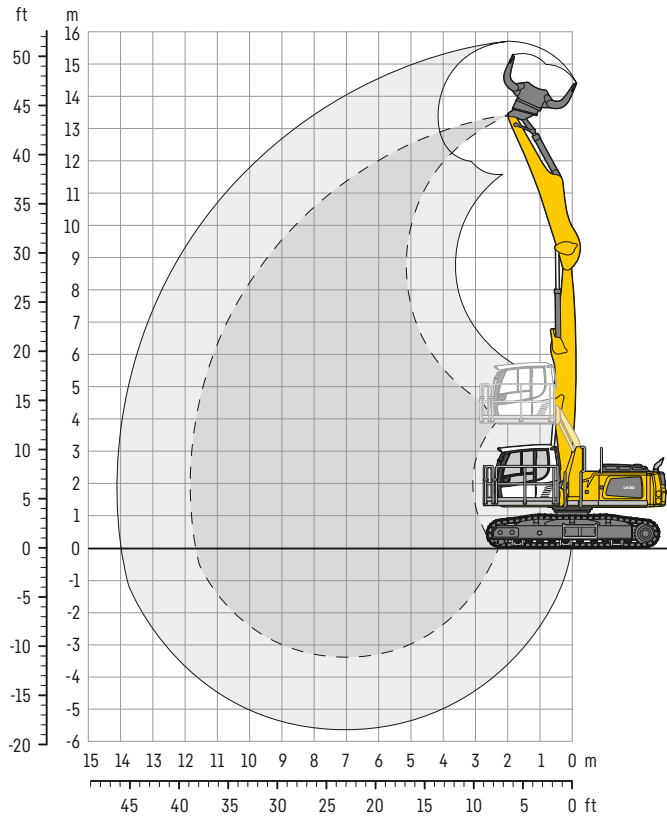

Dimensions

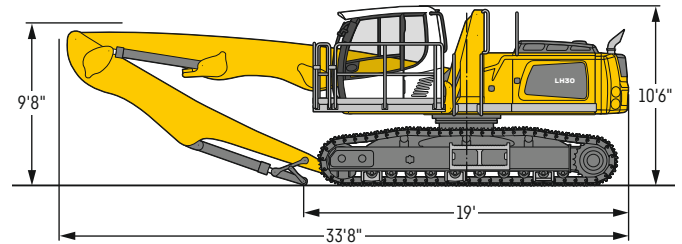

Operating weight and ground pressure

The operating weight includes the basic machine with hydr. cab elevation, straight boom 22'4", stick with tipping kinematics 16'5" and sorting grab SG 30B / 1.11yd³ perforated shells.

Weight	69,700 lb
Pad width	24"
Ground pressure	on request

ft	Undercarriage	10 ft		15 ft		20 ft		25 ft		30 ft		35 ft		40 ft		45 ft		ft in		
		☞	☞	☞	☞	☞	☞	☞	☞	☞	☞	☞	☞	☞	☞	☞	☞	☞	☞	☞
40	EW			18,9*	18,9*													14,4*	14,4*	18' 6"
35	EW					17,3*	17,3*	13,0*	13,0*									11,2*	11,2*	25'10"
30	EW					16,7*	16,7*	14,5*	14,5*	11,4*	11,4*							9,9*	9,9*	30' 7"
25	EW					16,8*	16,8*	14,5*	14,5*	12,6*	12,6*							9,2*	9,2*	34'
20	EW			19,5*	19,5*	17,5*	17,5*	14,7*	14,7*	12,7*	12,7*	10,4	10,8*					8,8*	8,8*	36' 4"
15	EW	15,2*	15,2*	23,2*	23,2*	18,6*	18,6*	15,2*	15,2*	12,8*	12,8*	10,3	10,7*					8,6*	8,6*	37'11"
10	EW	41,3*	41,3*	26,6*	26,6*	19,7*	19,7*	15,7*	15,7*	12,8*	12,8*	10,2	10,5*					8,3*	8,3*	38' 8"
5	EW			27,9*	27,9*	20,2*	20,2*	15,7*	15,7*	12,6*	12,6*	10,0*	10,0*					7,3*	7,3*	38'10"
0	EW	3,4*	3,4*	17,8*	17,8*	19,5*	19,5*	15,1*	15,1*	11,8*	11,8*	9,0*	9,0*					6,2*	6,2*	38' 5"
- 5	EW			17,1*	17,1*	17,3*	17,3*	13,4*	13,4*	10,3*	10,3*	7,1*	7,1*					6,2*	6,2*	36'
-10	EW					13,5*	13,5*	10,5*	10,5*									7,9*	7,9*	29' 5"

☞ Height ☞ Can be slewed through 360° ☞ In longitudinal position of undercarriage ☞ Max. reach * Limited by hydr. capacity

The lift capacities on the stick end without attachment are stated in lb x 1,000 and can be slewed through 360° on a firm, level supporting surface. Capacities are valid for 24" wide triple grouser pads. Indicated loads based on the ISO 10567 standard and do not exceed 75% of tipping or 87% of hydraulic capacity. The lift capacity of the unit is limited by its stability, the lifting capability of the hydraulic elements, or the maximum permissible lifting capacity of the load hook.

Attachments

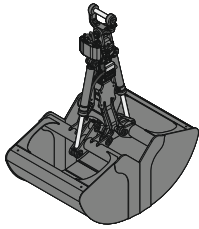

Grab for loose material

Shells for loose material with cutting edge (without teeth)

Grab model GMZ 40		Shells for loose material with cutting edge (without teeth)											
Shell specification		Standard						Wide					
Width of shells	ft in	3'11"	4'11"	5'9"	6'3"	7'1"	8'2"	3'11"	4'11"	5'9"	6'7"	7'5"	8'2"
Capacity	yd ³	2.75	3.27	3.92	4.58	5.23	5.88	1.57	1.96	2.29	2.62	2.94	3.27
Weight	lb	3,781	4,101	4,365	4,530	5,104	5,445	3,340	3,616	3,847	4,079	4,464	4,696

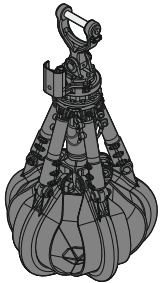

Multi-tine grab

		open		semi-closed		closed	
Grab model GM 64 (4 tines)							
Capacity	yd ³	0.52	0.78	0.52	0.78	0.52	0.78
Weight	lb	1,765	2,005	2,070	2,335	2,425	2,790
Grab model GM 65 (5 tines)							
Capacity	yd ³	0.52	0.78	0.52	0.78	0.52	0.78
Weight	lb	2,590	2,890	2,975	3,285	3,010	3,540

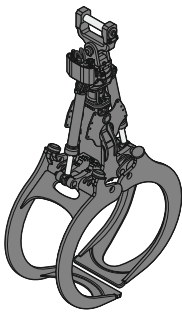

Wood grab

Grab model GM 20B round-shaped (complete overlapping, vertical cylinders)							
Size	yd ²	1.20	1.55	1.79	2.03	2.27	
Cutting width	ft in	2'8"	2'8"	2'8"	2'8"	2'8"	
Height of grab, closed	ft in	8'5"	8'9"	8'11"	9'3"	9'6"	
Weight	lb	3,405	3,470	3,515	3,585	3,880	

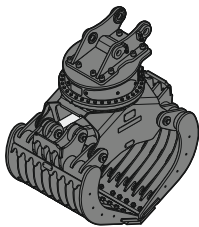

Sorting grab

		ribbed		perforated		ribbed		perforated	
Grab model SG 30B									
Width of shells	ft in	3'3"	3'3"	3'11"	3'11"	4'7"	4'7"		
Capacity	yd ³	0.98	1.11	1.18	1.31	1.37	1.50		
Max. closing force	lbf	17,985	17,985	17,985	17,985	17,985	17,985		
Weight incl. adapter plate SWA	lb	3,890	3,715	4,135	3,880	4,365	4,045		



Load hook

Max. load	lb	27,560
Height with suspension	ft in	3'1"
Weight	lb	300

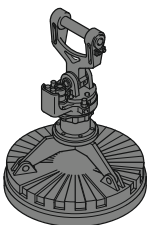

Magnet devices / lifting magnets

Generator	kW	13/17	13/17
Electromagnet with suspension			
Power	kW	8.8	10
Diameter of magnet	ft in	4'1"	4'5"
Weight	lb	2,890	3,750

* only magnet plate

Equipment



Undercarriage

	30 M	35 M	30 C
4-wheel steering		+	
Trailer coupling	+	+	
Track pads, variants			+
Individual control outriggers	+	+	
Shuttle axle lock, automatic	●	●	
Outrigger monitoring system	+	+	
Dozer blade	+	+	
Tires, variants	+	+	
Protection for travel drive	+	+	
Protection for piston rods, outriggers	+	+	
Two storage compartments	●	●	
Undercarriage, variants			+



Uppercarriage

	30 M	35 M	30 C
Uppercarriage right side light, 1 piece, LED	●	●	●
Uppercarriage rear light, 2 pieces, LED	+	+	+
Heavy counterweight	+		
Refuelling system with filling pump	+	+	+
Railing on uppercarriage	+	+	+
Generator	+	+	+
Main battery switch for electrical system	●	●	●
Amber beacon, at uppercarriage, LED double flash	+	+	+
Protection for headlights	+	+	+
Protection for rear lights	+	+	+
Tool equipment, extended	+	+	+



Hydraulic system

	30 M	35 M	30 C
Electronic pump regulation	●	●	●
Liebherr hydraulic oil from -4°F to +104°F	●	●	●
Liebherr hydraulic oil, biologically degradable	+	+	+
Magnetic rod in hydraulic tank	●	●	●
Bypass filter	+	+	+
Preheating hydraulic oil	+	+	+



Engine

	30 M	35 M	30 C
Fuel anti-theft device	+	+	+
Air pre-filter with dust discharge	+	+	+
Automatic engine shut-down (time adjustable)	+	+	+
Preheating fuel	+	+	+
Preheating coolant	+	+	+
Preheating engine oil*	+	+	+



Cooling system

	30 M	35 M	30 C
Radiator, large-mesh, for dust-intensive operation	●	●	●
Reversible fan drive	+	+	+
Protective grid in front of cooler intake	●	●	●



Cab

	30 M	35 M	30 C
Stabilizer, control lever, left console	+	+	
Stabilizer, proportional control on left joystick	●	●	
Cab lights rear, halogen	+	+	+
Cab lights rear, LED	+	+	+
Cab lights front, halogen	+	+	+
Cab lights front, halogen (under rain cover)	●	●	●
Cab lights front, LED	+	+	+
Cab lights front, LED (under rain cover)	+	+	+
Armrest adjustable	●	●	●
Slewing gear brake Comfort, button on the left or right joystick	+	+	+
Operator's seat Comfort	●	●	●
Operator's seat Premium	+	+	+
Driving alarm			
(acoustic signal is emitted during travel, can be switched ON/OFF)	+	+	+
Fire extinguisher	+	+	+
Footrest	+	+	+
Horn, button on left joystick	●	●	●
Joystick steering (max. 7.5 mph)	●	●	
Joystick and wheel steering (slim version)	+	+	
Cab elevation, hydraulic (LHC)	●	●	●
Cab elevation, hydraulic with tilt function (LHC)	+	+	+
Cab elevation, rigid (LFC)	+	+	+
Automatic air conditioning	●	●	●
Wheel steering (slim version)	+	+	
LiDAT, vehicle fleet management	●	●	●
Proportional control	●	●	●
Radio Comfort, control via display with handsfree set	+	+	+
Preparation for radio installation	●	●	●
Back-up alarm			
(acoustic signal is emitted traveling backward, can not be switched off)	+	+	
Amber beacon, on cab, LED double flash	+	+	+
Windows made from impact-resistant laminated safety glass	+	+	+
Windscreen wiper, roof	+	+	+
Windshield wiper, entire windshield	●	●	●
FOPS top guard	+	+	+
FGPS front guard, tiltable	+	+	+
Sun visor	+	+	+
Left control console, folding	●	●	●



Equipment

	30 M	35 M	30 C
Boom lights, 2 pieces, halogen	●	●	●
Boom lights, 2 pieces, LED	+	+	+
Stick lights, 2 pieces, halogen	●	●	●
Stick lights, 2 pieces, LED	+	+	+
Filter system for attachment	+	+	+
Height limitation and stick shutoff, electronically	+	+	+
Boom cylinder cushioning	+	+	+
Stick camera (with separate monitor), bottom side, with protection	+	+	+
Liebherr multi coupling system	+	+	+
Liebherr quick coupler, hydraulic	+	+	+
Pipe fracture safety valves hoist cylinders	●	●	●
Pipe fracture safety valves stick cylinders	●	●	●
Quick coupling system Solidlink	+	+	+
Quick coupling system MH 40B	+	+	+
Protection for piston rods, hoist cylinder	+	+	+
Protection for piston rods, stick cylinder	+	+	+
Overload warning device	+	+	+



Complete machine

	30 M	35 M	30 C
Lubrication			
Lubrication undercarriage, manually - decentralized (grease points)	●	●	
Lubrication undercarriage, manually - centralized (one grease point)	+	+	
Central lubrication system for uppercarriage and equipment, automatically	●	●	●
Central lubrication system for undercarriage, automatically	+	+	
Centralized lubrication extended for attachment	+	+	+
Special coating			
Special coating, variants	+	+	+
Monitoring			
Rear view monitoring with camera	●	●	●
Side view monitoring with camera	●	●	●

● = Standard, + = Option

* = country-dependent

Options and /or special equipment, supplied by vendors other than Liebherr, are only to be installed with the knowledge and approval of Liebherr in order to retain warranty.

The Liebherr Group



Global and independent: more than 70 years of success

Liebherr was founded in 1949. With the development of the world's first mobile tower crane, Hans Liebherr laid the foundations of a successful family business which today comprises more than 140 companies on all continent and employs nearly 50,000 people. The parent company of the Group is Liebherr-International AG in Bulle (Switzerland), whose associates are exclusively members of the Liebherr family.

Technology leadership and pioneering spirit

Liebherr regards itself as a pioneer. This spirit has enabled the company to make a decisive contribution to the technological history of many industries. Today, employees around the world still share the courage of the company founder to take new paths. They are all united by a passion for technology and fascinating products and the determination to perform outstanding work for their customers.

Widely diversified product portfolio

Not only is Liebherr one of the biggest construction equipment manufacturers in the world, it also provides high-quality, user-oriented products and services in a wide range of other areas. The product portfolio includes the segments earthmoving, material handling technology, deep foundation machines, mining, mobile and crawler cranes, tower cranes, concrete technology, maritime cranes, aerospace and transportation systems, gear technology and automation systems, refrigeration and freezing, components and hotels.

Customized solutions and maximum customer benefit

Liebherr solutions are characterized by maximum precision, outstanding implementation and exceptional longevity. Its mastery of key technologies enables the company to offer its customers customized solutions. For Liebherr, customer focus does not end with the product; it also encompasses a wide range of services that make a real difference.

www.liebherr.us

WARNING

Breathing diesel engine exhaust exposes you to chemicals known to the State of California to cause cancer and birth defects or other reproductive harm.

- Always start and operate the engine in a well-ventilated area.
- If in an enclosed area, vent the exhaust to the outside.
- Do not modify or tamper with exhaust system.
- Do not idle the engine except as necessary.

For more information go to www.P65warnings.ca.gov/diesel.

WARNING

This product can expose you to chemicals including lead and lead compounds, which are known to the State of California to cause cancer and birth defects or other reproductive harm.

For more information go to www.P65warnings.ca.gov.

Liebherr USA, Co.

Construction Equipment Division • 4800 Chestnut Avenue • Newport News, VA 23607, USA • Phone +1 (757) 240 4250
construction.usa@liebherr.com • www.liebherr.us • www.facebook.com/LiebherrConstruction